

SAMPLE CONTENT

PERFECT

PHYSICS

**Vol.
I**



Based on Latest Paper Pattern and Textbook



Leaning of race-horses:

By leaning to the side and hitting the ground with its hooves at an angle, the racehorse provides itself the necessary centripetal force and gives itself the sideways acceleration necessary to make a sharp change in direction.

Std. XII Sci.

Mr. Collin Fernandes
M.Sc.

Ms. Meenal Iyer
M.Sc., B.Ed.

Ms. Ketki Deshpande
M.Sc.

Target Publications® Pvt. Ltd.

PERFECT PHYSICS (Vol. I)

Std. XII Sci.

Salient Features

- Written as per **Latest Board Paper Pattern**
- Subtopic-wise segregation for powerful concept building
- Complete coverage of Textual Exercise Questions, Intext Questions and Numericals
- Marks provided to the Questions as per relevant weightage wherever deemed necessary
- Relevant Previous Years' Board Questions:
March 2013 to July 2023
- Each chapter contains:
 - 'Quick Review' of the chapter for quick revision
 - 'Apply Your Knowledge' section for application of concepts
 - 'Important Formulae' and 'Solved Examples' to cover numerical aspect in detail
 - 'Exercise' to provide Theory questions, Numericals and MCQs for practice
 - 'Competitive Corner' to give the glimpse of prominent competitive examinations
 - 'Topic Test' at the end of each chapter for self-assessment
- Includes Important Features for holistic learning:
 - *About the Chapter* - *Reading Between the Lines* - *NCERT Corner*
 - *Enrich Your Knowledge* - *Gyan Guru* - *Strategy*
 - *Connections* - *Caution*
- Q.R. codes provide:
 - The Video/pdf links boosting conceptual retention
 - Solutions of Numericals for Practice and Topic Tests
 - Model Question Paper along with Solution
- Includes Board Question Paper of February 2024 (Solution in pdf format through QR code)

Printed at: **Prabodhan Prakashan Pvt. Ltd.**, Navi Mumbai

© Target Publications Pvt. Ltd.

No part of this book may be reproduced or transmitted in any form or by any means, C.D. ROM/Audio Video Cassettes or electronic, mechanical including photocopying; recording or by any information storage and retrieval system without permission in writing from the Publisher.

PREFACE

Perfect Physics Vol. I, Std. XII Sci. is intended for every Maharashtra State Board aspirant of Std. XII, Science. The scope, sequence, and level of the book are consistent with the latest textbook released by Maharashtra State board.

At a crucial juncture of cracking a career defining board examination, we wanted to create a book that not just develops the necessary knowledge, tools and skills required to excel in the examination in students but also enables them to appreciate the beauty of subject and piques their curiosity.

We believe the students need meaningful content presented in a way that is easy to read and understand rather than being mired down with facts and information. They do much better when they understand why Physics is relevant to their everyday lives.

Comprehension of Physics eventuates naturally when subject is studied systematically with sincere and dedicated efforts.

The Core of Physics lies in its concepts. Therefore, writing clear and lucid explanations of fundamental concepts is our highest priority. Moreover, special care has been taken to ensure that the topics are presented in a logical order.

Every chapter in this book begins with '*About the Chapter*' that offers a brief introduction of the chapter and orients students towards the topic from examination point of view. The coherent Question/Answer approach helps students expand their horizon of understanding of the concepts. Though Physics is communicated in English, it is expressed in Mathematics. To help the students hone their problem-solving skills, ample numericals of different types are amalgamated. Log calculations are presented as seemed necessary to give students idea of solutions expected in board examination.

The scope of the book extends beyond the State Board examination as it also offers a plethora of Multiple Choice Questions (MCQs) in order to familiarize the students with the pattern of competitive examinations.

In addition, the Topic-Test has been carefully crafted to focus on concepts, thus providing the students with a quick opportunity for self-assessment and giving them an increased appreciation of chapter-preparedness. '*Model Question Paper*' based on latest paper pattern is provided along with solution which can be accessed through QR code to help students assess their preparedness for final board examination.

We believe; amongst building concepts, advancing into numbers and equations, it is essential to ponder underlying implications of subject. Students should read from references, visit authentic websites, watch relevant fascinating links and even experiment on their own following proper safety guidelines. We have added several features to nurture the curiosity of students.

As famous hat detective Sherlock Holmes has pointed, **people see, they do not observe**. By becoming attentive to their surroundings students can easily perceive how Physics has touched entire spectrum of life. The very realization is catalytic enough for students to admire and further dive into this compelling subject.

Our **Perfect Physics Vol. I, Std. XII Sci.** adheres to our vision and achieves several goals: **building concepts, developing competence to solve numericals, recapitulation, self-study, self-assessment and student engagement**—all while encouraging students toward cognitive thinking.

The flow chart on the adjacent page will walk you through the key features of the book and elucidate how they have been carefully designed to maximize the student learning.

We hope the book benefits the learner as we have envisioned.

Publisher

Edition: Sixth

The journey to create a complete book is strewn with triumphs, failures and near misses. If you think we've nearly missed something or want to applaud us for our triumphs, we'd love to hear from you.

Please write to us on: mail@targetpublications.org

KEY FEATURES

'About the Chapter' is a short introduction designed to stimulate students' appetite for the topic.

About the chapter

Reading between the lines

Reading between the lines provides elaboration or missing fragments of concept which is essential for complete understanding of the concept.

Strategy provides a step-by-step process to break a complex numerical problem into simpler parts.

Strategy

Caution

Caution helps students to be watchful against commonly made mistakes.

NCERT Corner covers information from NCERT textbook relevant to topic.

NCERT Corner

Connections

Connections enable students to interlink concepts covered in different chapters.

QR code provides:

- i. Access to a video/PDF in order to boost understanding of a concept or activity
- ii. Solutions to Numericals for Practice
- iii. Solutions to the Topic Tests
- iv. Model Question Paper with solution
- v. Solution to Board Question Paper of February 2024

QR Codes

Continued...

KEY FEATURES

Enrich Your Knowledge

Enrich Your Knowledge presents fascinating information about the concept covered.

Gyan Guru illustrates real life applications or examples related to the concept discussed.

GG-Gyan Guru

Apply Your Knowledge

Apply Your Knowledge includes challenging questions.

Quick review includes tables/ flow chart to summarize the key points in chapter.

Quick Review

Important Formulae

Important Formulae includes all of the key formulae in the chapter.

Competitive Corner includes selective questions from prominent [NEET (UG), JEE (Main), MHT CET] competitive exams based entirely on the syllabus covered in the chapter.

Competitive Corner

Board Questions

Includes relevant Board questions from March 2013 to July 2023

PAPER PATTERN

- There will be single question paper of 70 Marks and practical examination of 30 Marks in Physics.
- Duration of the question paper will be 3 hours.

Section A: (18 Marks)

This section will contain Multiple Choice Questions and Very Short Answer (VSA) type of questions.

There will be 10 MCQs and 8 VSA type of questions, each carrying one mark.

Students will have to attempt all these questions.

Section B: (16 Marks)

This section will contain 12 Short Answer (SA-I) type of questions, each carrying 2 marks.

Students will have to attempt any 8 questions.

Section C: (24 Marks)

This section will contain 12 Short Answer (SA-II) type of questions, each carrying 3 marks.

Students will have to attempt any 8 questions.

Section D: (12 Marks)

This section will contain 5 Long Answer (LA) type of questions, each carrying 4 marks.

Students will have to attempt any 3 questions.

Distribution of Marks According to the Type of Questions

Type of Questions		
MCQ	1 Mark each	10 Marks
VSA	1 Mark each	8 Marks
SA - I	2 Marks each	16 Marks
SA - II	3 Marks each	24 Marks
LA	4 Marks each	12 Marks

Percentage wise distribution of marks	
Theory	63%
Numerical	37%

Disclaimer

This reference book is transformative work based on latest Textbook of Std. XII Physics published by the Maharashtra State Bureau of Textbook Production and Curriculum Research, Pune. We the publishers are making this reference book which constitutes as fair use of textual contents which are transformed by adding and elaborating, with a view to simplify the same to enable the students to understand, memorize and reproduce the same in examinations.

This work is purely inspired upon the course work as prescribed by the Maharashtra State Bureau of Textbook Production and Curriculum Research, Pune. Every care has been taken in the publication of this reference book by the Authors while creating the contents. The Authors and the Publishers shall not be responsible for any loss or damages caused to any person on account of errors or omissions which might have crept in or disagreement of any third party on the point of view expressed in the reference book.

© reserved with the Publisher for all the contents created by our Authors.

No copyright is claimed in the textual contents which are presented as part of fair dealing with a view to provide best supplementary study material for the benefit of students.

CONTENTS

Chapter No.	Chapter Name	Marks without option	Marks with option	Page No.
1	Rotational Dynamics	5	7	1
2	Mechanical Properties of Fluids	5	7	64
3	Kinetic Theory of Gases and Radiation	5	7	129
4	Thermodynamics	5	7	170
5	Oscillations	4	5	221
6	Superposition of Waves	4	6	274
7	Wave Optics	5	7	327
	Board Question Paper: February 2024 (Solution in pdf format through QR code)			391
	<ul style="list-style-type: none"> Scan the given Q.R. Code in <i>Quill – The Padhai App</i> to view the Model Question Paper with Solution. 			

Chapters 8 to 16 are a part of **Std. XII: Perfect Physics (Vol. II)**

[Reference: Maharashtra State Board of Secondary and Higher Secondary Education, Pune - 04]

- Note:**
1. * mark represents Textual question.
 2. # mark represents Intext question.
 3. + mark represents Textual examples.
 4. 🔔 symbol represents textual questions that need external reference for an answer.

Scan the adjacent QR Code to know more about our **“Model Question Papers with solutions”** book for Std. XII (Sci.) and Gear up yourself to score more in the XII Board Examination.



Scan the adjacent QR Code to know more about our **“Board Questions with Solutions”** book for Std. XII (Sci.) and Learn about the types of questions that are asked in the XII Board Examination.



1

Rotational Dynamics

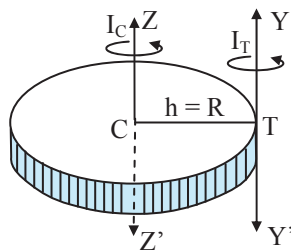

About the chapter...

The chapter introduces students about various theories put forward to depict circular motion, rotational motion and rolling motion. It proceeds to describe various concepts like vertical circular motion, conical pendulum, moment of inertia, rolling motion, etc. in details.

Chapter is allotted weightage of 7 marks with option and 5 marks without option. Concepts, derivations and numericals, together form the backbone of the chapter. Therefore, equal emphasis should be given to theory questions, derivations, and numericals. The chapter is also important from MCQ point of view.

CONTENTS AND CONCEPTS

- | | |
|--|--|
| <ul style="list-style-type: none"> 1.1 Introduction 1.2 Characteristics of Circular Motion 1.3 Applications of Uniform Circular Motion 1.4 Vertical Circular Motion 1.5 Moment of Inertia as an Analogous Quantity for Mass 1.6 Radius of Gyration | <ul style="list-style-type: none"> 1.7 Theorem of Parallel Axes and Theorem of Perpendicular Axes 1.8 Angular Momentum or Moment of Linear Momentum 1.9 Expression for Torque in Terms of Moment of Inertia 1.10 Conservation of Angular Momentum 1.11 Rolling Motion |
|--|--|

1.1 Introduction

Q.1. What is the difference between revolution and rotation of an object? [1 Mark]

Ans: During revolution, the object (every particle in the object) undergoes circular motion about some point outside the object or about some other object. During rotation, the motion is about an axis of rotation passing through the object.

1.2 Characteristics of Circular Motion

Q.2. Can you recall? (Textbook page no. 1)

What is circular motion? [1 Mark]

Ans: Motion of an object around a circular path is called as circular motion.

Q.3. State the characteristics of circular motion.

[2 Marks]

Ans:

- i. **Accelerated motion:** As the direction of velocity changes at every instant, it is an accelerated motion.
- ii. **Periodic motion:** During the motion, the particle repeats its path along the same trajectory. Thus, the motion is periodic.

Q.4. Can you recall? (Textbook page no. 1)

What are kinematical equations of motion?

[2 Marks]

Ans: Kinematical equations of motion:

No.	Linear motion	Rotational motion
i.	$v = u + at$	$\omega = \omega_0 + \alpha t$
ii.	$s = ut + \frac{1}{2} at^2$	$\theta = \omega_0 t + \frac{1}{2} \alpha t^2$
iii.	$v^2 = u^2 + 2as$	$\omega^2 = \omega_0^2 + 2\alpha\theta$

READING BETWEEN THE LINES



where,

v = Final linear velocity,
 u = Initial linear velocity,
 a = Linear acceleration,
 s = Linear displacement,
 ω = Final angular velocity,
 ω_0 = Initial angular velocity,
 α = Angular acceleration,
 θ = Angular displacement,
 t = Time

Page no. **2** to 8 are purposely left blank.

To see complete chapter buy **Target Notes** or **Target E-Notes**

**Ans:**

- When a four-wheeler takes a turn on a curve unbanked road then it has a tendency to skid away from centre of the road.
- The torque that prevents it from skipping away from the turn arises as the normal force on the outside wheels is larger than the normal force on the inside wheels.

iii. **Overturning of a vehicle:**

- When a car moves in a circular path with speed more than a certain maximum speed, then it overturns even if friction is sufficient to avoid skidding and its inner wheel leaves the ground first.

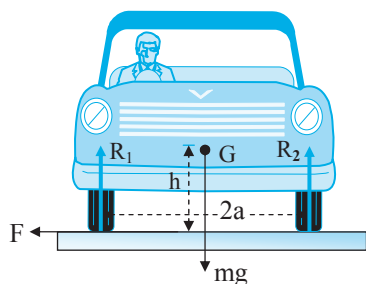

- Let weight of the car = mg , speed of the car = v , radius of the curved path = r
Distance between the centre of wheels of the car = $2a$
Height of the centre of gravity (G) of the car from the road level = h
Reaction on the inner wheel of the car by the ground = R_1
Reaction on the outer wheel of the car by the ground = R_2
- When a car moves in a circular path, horizontal frictional force F provides the required centripetal force.

$$\text{i.e., } F = \frac{mv^2}{r} \quad \dots(1)$$

- For rotational equilibrium, by taking the moment of forces R_1 , R_2 and F about G we get,
 $Fh + R_1a = R_2a \quad \dots(2)$

$$\text{As there is no vertical motion,} \\ R_1 + R_2 = mg \quad \dots(3)$$

By solving (1), (2) and (3) we get,

$$R_1 = \frac{1}{2}m \left[g - \frac{v^2h}{ra} \right] \quad \dots(4) \text{ and}$$

$$R_2 = \frac{1}{2}m \left[g + \frac{v^2h}{ra} \right] \quad \dots(5)$$

- From equation (4), if v increases, value of R_1 decreases and for $R_1 = 0$,

$$\frac{v^2h}{ra} = g \text{ or } v = \sqrt{\frac{gra}{h}}$$

i.e., the maximum speed of a car without overturning on a flat road is given by $v = \sqrt{\frac{gra}{h}}$

- As maximum speed is independent of mass of the vehicle, loading the vehicle does not play a vital role for toppling.
- For safe driving of vehicle on curved unbanked road, the speed should be $v < \sqrt{\frac{gra}{h}}$. As friction is not reliable, at high speeds and sharp turns, friction is not able to provide the required centripetal force. Friction causes unnecessary wear and tear of the tyres.

II. Determine the angle to be made with the vertical by a two wheeler rider while turning on a horizontal track. [3 Marks]

Ans: Refer Q.29

III. We have mentioned about static friction between road and the tyres. Why is it static? What about the kinetic friction between road and the tyres? [2 Marks]

Ans:

- The patch of tyres (made of rubber) which is actually touching the road is not moving with respect to the road. It is static for a certain period every revolution.
- Hence, static friction acts between tyres of car and road but not kinetic friction even when the tyres are rolling.

IV. What do you do if your vehicle is trapped on a slippery or a sandy road? What is the physics involved? [2 Marks]

Ans: Vehicles are designed to drive on the road, where there is natural traction. A slippery or a sandy road reduces that traction and makes it tough to move.

Therefore, when a vehicle is trapped on a slippery or a sandy road, an additional frictional force is required. This can be achieved by placing car mats (or pieces of carpet, sticks, gravel, rocks, etc.) under the stuck tire, with the rest of the mat in front of the tire. A vehicle should be driven slowly forward until solid ground is reached.

**CAUTION**

In the above mentioned situation, spinning of wheels of vehicles should be avoided since one may lose more traction due to rapidly moving wheels and vehicle would tend to slide deeper into slippery or sandy road.

Page no. **110** to **211** are purposely left blank.

To see complete chapter buy **Target Notes** or **Target E-Notes**



ENRICH YOUR KNOWLEDGE



- None of the parameters (including the linear and angular accelerations) are constant during such a motion and hence kinematical equations are not applicable.
- Any higher speeds than the minimum speeds at the uppermost and the lowermost points obeying the equation are allowed.
- In reality, we have to continuously supply some energy to overcome the air resistance.

Q.68. Do you know? (Textbook page no. 12)

Roller coaster is a common event in the amusement parks. During this ride, all the parts of the vertical circular motion described above can be experienced. The major force that we experience during this is the normal reaction force. Those who have experienced this, should try to recall the changes in the normal reaction experienced by us during various parts of the track.

[Students are expected to perform the above activity on their own.]

Q.69. What is meant by mass tied to a rod? How is it different from mass tied to a string?

[2 Marks]

Ans:

- A bob (point mass) tied to a (practically massless and rigid) rod and whirled along a vertical circle.
- The basic difference between the rod and the string is that the string needs some tension at all the points, including the uppermost point while mass tied to a rod doesn't need tension at any point.

Q.70. State the expression for difference in tension at the lowermost and uppermost point when mass is tied to a rod.

[1 Mark]

Ans: $T_{\text{lowermost}} - T_{\text{uppermost}} = 6mg$ **Q.71. Write the expressions for minimum velocity at lower most and at horizontal position for mass tied to rod performing vertical circular motion.**

[1 Mark]

Ans:

- $(v_{\text{lowermost}})_{\text{min}} = 2\sqrt{rg}$
- $(v_{\text{horizontal position}})_{\text{min}} = \sqrt{2rg}$

Q.72. Write short note on sphere of death.

[2 Marks]

Ans:

- This is a popular show in a circus. During this, two-wheeler rider (or riders) undergo rounds inside a hollow sphere.
- Starting with small horizontal circles, they eventually perform revolutions along vertical circles.
- The dynamics of this vertical circular motion is the same as that of the point mass tied to the string, except that the force due to tension T is replaced by the normal reaction force N .
- The linear speed is more for larger circles but angular speed (frequency) is more for smaller circles (while starting or stopping). This is as per the theory of conical pendulum.

Q.73. Explain the expression for upper limit on the speed when vehicle is at the top of a convex overbridge.

[3 Marks]

Ans:

- Consider a vehicle at the top of a convex overbridge as shown in the figure.

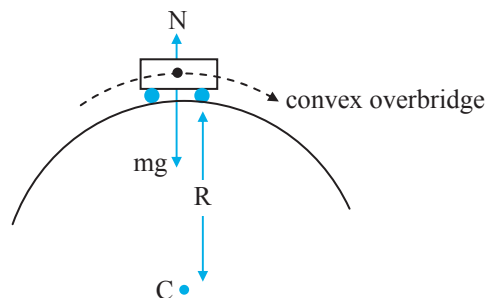

- During its motion (part of vertical circular motion), forces acting on the vehicle are
 - weight (mg)
 - normal reaction force (N), both along the vertical line (topmost position).
- The resultant of these two must provide the necessary centripetal force (vertically downwards) if the vehicle is at the uppermost position.
- Thus, if v is the speed at the uppermost point,

$$mg - N = \frac{mv^2}{r}$$

- As the speed is increased, N goes on decreasing. Normal reaction is an indication of contact.
- Thus, for just maintaining contact, $N = 0$. This imposes an upper limit on the speed as

$$v_{\text{max}} = \sqrt{rg}$$

Page no. **23** to **27** are purposely left blank.

To see complete chapter buy **Target Notes** or **Target E-Notes**



Ans:

- i. Refer Q.87
- ii. Radius of gyration of a body about its given axis is defined as the distance between the axis of rotation and a point at which the whole mass of the body is supposed to be concentrated, so as to possess the same moment of inertia as that of body about the same axis.
- iii. Centre of mass of a body is a point at which the whole mass of the body is supposed to be concentrated.
- iv. Mathematically the radius of gyration is the root mean square distance of the object's parts from either its centre of mass or a given axis.
- v.
 - a. Radius of gyration depends upon,
 1. distribution of mass of the body
 2. position of axis of rotation
 3. shape and size of the body
 - b. Radius of gyration of body is independent of total mass of the body.
- vi. If $K_r = K_d$,
 $I_r = M_r K_r^2$ and $I_d = M_d K_d^2$
 $\therefore M_r R_r^2 = M_r K_r^2$ and $\frac{1}{2} M_d R_d^2 = M_d K_d^2$
 $\therefore K_r = R_r$ and $K_d = \frac{R_d}{\sqrt{2}}$
 $\therefore R_r = \frac{R_d}{\sqrt{2}}$
 $\therefore R_d = \sqrt{2} R_r$
 i.e., Radius of disc is equal to $\sqrt{2}$ times the radius of ring.

SOLVED EXAMPLES

Q.92. A solid sphere of mass 6 kg and radius 2 metre is rotating about its diameter. Calculate the radius of gyration of the sphere. [2 Marks]

Solution:

Given: $M = 6 \text{ kg}$, $R = 2 \text{ m}$

To find: Radius of gyration (K)

Formula: $K = \sqrt{\frac{I}{M}}$

Calculation: Since, M.I of solid sphere, $I = \frac{2}{5} MR^2$

From formula,

$$K = \sqrt{\frac{\frac{2}{5} MR^2}{M}} = \sqrt{\frac{2}{5} R^2} = R \sqrt{\frac{2}{5}}$$

$$= \frac{R}{5} \sqrt{10} = \frac{2}{5} \times 3.162$$

$\therefore K = 1.26 \text{ m}$

Ans: The radius of gyration of the sphere is **1.26 m**.



Connections

You will study formula, $I = 2MR^2/5$ in subtopic 1.7 of this chapter.

Q.93. A torque of 400 N m acting on a body of mass 40 kg produces an angular acceleration of 20 rad/s². Calculate the moment of inertia and radius of gyration of the body. [2 Marks]

Solution:

Given: $\tau = 400 \text{ Nm}$, $M = 40 \text{ kg}$, $\alpha = 20 \text{ rad/s}^2$

To find: Moment of inertia (I),
radius of gyration (K)

Formulae: i. $\tau = I\alpha$ ii. $K = \sqrt{\frac{I}{M}}$

Calculation: From formula (i),

$$I = \frac{\tau}{\alpha} = \frac{400}{20} = 20 \text{ kg m}^2$$

From formula (ii),

$$K = \sqrt{\frac{20}{40}} = \sqrt{\frac{1}{2}} = \sqrt{0.5} = 0.707 \text{ m}$$

Ans: The moment of inertia and radius of gyration of the body are **20 kg m²** and **0.707 m** respectively.



Connections

You will study formula, $\tau = I\alpha$ in subtopic 1.9 of this chapter.

1.7 Theorem of Parallel Axes and Theorem of Perpendicular Axes

Q.94. How is theorem of parallel and perpendicular axes useful? [2 Marks]

Ans:

- i. Expressions of moment of inertia of regular geometrical shapes are about their axis of symmetry and are derived by integration.
- ii. However, every time the axis need not be the axis of symmetry. In simple transformations it may be parallel or perpendicular to the symmetrical axis.
- iii. For example, if a rod is rotated about one of its ends, the axis is parallel to its axis of symmetry.
- iv. If a disc or a ring is rotated about its diameter, the axis is perpendicular to the central axis.
- v. In such cases, simple transformations are possible in the expressions of moment of inertia. These are called theorem of parallel axes and theorem of perpendicular axes.

Page no. **29** to **43** are purposely left blank.

To see complete chapter buy **Target Notes** or **Target E-Notes**



QUICK REVIEW

Physical quantities
<ul style="list-style-type: none"> $I = \sum mr^2$ $K.E. = \frac{1}{2} I\omega^2$ $\tau = I\alpha$ $L = I\omega$ $K = \sqrt{\frac{I}{M}}$

Parallel axes theorem
<p>Statement: The moment of inertia (I_o) of an object about any axis is the sum of its moment of inertia (I_c) about an axis parallel to the given axis, and passing through the centre of mass and the product of the mass of the object and the square of the distance between the two axes, $I_o = I_c + Mh^2$</p>

Perpendicular axes theorem
<p>Statement: The moment of inertia (I_z) of a laminar object about an axis (z) perpendicular to its plane is the sum of its moment of inertias about two mutually perpendicular axes (x and y) in its plane, all the three axes being concurrent, $I_z = I_x + I_y$</p>

Rolling motion
Total energy, $E = \frac{1}{2} Mv^2 \left(1 + \frac{K^2}{R^2} \right)$
Velocity, $v = \sqrt{\frac{2gh}{1 + \frac{K^2}{R^2}}}$
Acceleration, $a = \frac{g \sin \theta}{1 + \frac{K^2}{R^2}}$
Useful values:
$\left(\frac{K^2}{R^2} \right)_{\text{Solid sphere}} = \frac{2}{5}; \left(\frac{K^2}{R^2} \right)_{\text{hollow cylinder}} = 1,$
$\left(\frac{K^2}{R^2} \right)_{\text{Solid Cylinder}} = \frac{1}{2}; \left(\frac{K^2}{R^2} \right)_{\text{hollow sphere}} = \frac{2}{3}$

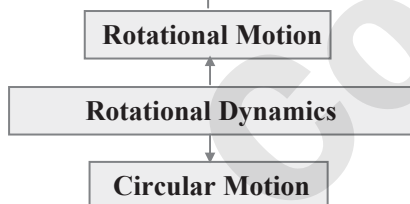

Uniform Circular Motion

Centripetal force

Centripetal force is directed along the radius towards the centre of a circle. In vector form, it is given by $\vec{F} = -\frac{mv^2}{r} \hat{r}_0$

Centrifugal force

Centrifugal force is directed along the radius away from the centre of a circle. In vector form, it is given by, $\vec{F} = +\frac{mv^2}{r} \hat{r}_0$

Banking of road

Unbanked road

Maximum possible speed, $v_{\max} = \sqrt{\mu_s rg}$
 Rider should bend through an angle, $\theta = \tan^{-1} \left(\frac{v^2}{rg} \right)$.
 Minimum safest velocity of a body for move in well of death, $v_{\min} = \sqrt{\frac{rg}{\mu_s}}$

Banked road

Angle of banking: $\theta = \tan^{-1} \left(\frac{v^2}{rg} \right)$
 Most safe speed, $v_s = \sqrt{rg \tan \theta}$
 $v_{\min} = \sqrt{rg \left(\frac{\tan \theta - \mu_s}{1 + \mu_s \tan \theta} \right)}$; $v_{\max} = \sqrt{rg \left(\frac{\tan \theta + \mu_s}{1 - \mu_s \tan \theta} \right)}$

Conical Pendulum

Angular frequency, $\omega = \sqrt{\frac{g}{L \cos \theta}}$
 Time Period, $T = 2\pi \sqrt{\frac{L \cos \theta}{g}}$
 Frequency, $n = \frac{1}{2\pi} \sqrt{\frac{g}{L \cos \theta}}$

Vertical Circular Motion

At lowest point:
 $v_L = \sqrt{5rg}$
 $T_L = \frac{mv_L^2}{r} + mg$
At highest point:
 $v_H = \sqrt{rg}$
 $T_H = \frac{mv_H^2}{r} - mg$
At midway point:
 $v_M = \sqrt{3rg}$
Difference between tension at lower most and uppermost point:
 $T_L - T_H = 6mg$



IMPORTANT FORMULAE

1. In U.C.M angular velocity:

$$\begin{array}{ll} \text{i. } \omega = \frac{v}{r} & \text{ii. } \omega = \frac{\theta}{t} \\ \text{iii. } \omega = 2\pi n & \text{iv. } \omega = \frac{2\pi}{T} \end{array}$$

2. Angular displacement:

$$\begin{array}{ll} \text{i. } \theta = \omega t & \text{ii. } \theta = \frac{2\pi t}{T} \\ \text{iii. } \theta = 2\pi n t & \end{array}$$

3. Angular acceleration:

$$\begin{array}{ll} \text{i. } \alpha = \frac{\omega_2 - \omega_1}{t} & \text{ii. } \alpha = \frac{2\pi}{t} (n_2 - n_1) \end{array}$$

4. Linear velocity:

$$\begin{array}{ll} \text{i. } v = r\omega & \text{ii. } v = 2\pi nr \end{array}$$

5. Centripetal acceleration or radial acceleration: $a = \frac{v^2}{r} = \omega^2 r$ 6. Tangential acceleration: $\vec{a}_T = \vec{\alpha} \times \vec{r}$

7. Centripetal force:

$$\begin{array}{ll} \text{i. } F_{CP} = \frac{mv^2}{r} & \text{ii. } F_{CP} = m r \omega^2 \\ \text{iii. } F_{CP} = 4\pi^2 m r n^2 & \text{iv. } F_{CP} = \frac{4\pi^2 m r}{T^2} \end{array}$$

$$\text{v. } F_{CP} = \mu mg = m\omega^2 r$$

8. Centrifugal force: $F_{CF} = -F_{CP}$ 9. Inclination of banked road: $\theta = \tan^{-1} \left(\frac{v^2}{rg} \right)$

10. On unbanked road:

- i. Maximum velocity of vehicle to avoid skidding on a curve unbanked road: $v_{\max} = \sqrt{\mu rg}$
- ii. Angle of leaning: $\theta = \tan^{-1} \left(\frac{v^2}{rg} \right)$

11. On banked road:

$$\text{i. Upper speed limit: } v_{\max} = \sqrt{rg \left[\frac{\mu_s + \tan \theta}{1 - \mu_s \tan \theta} \right]}$$

$$\text{ii. Lower speed limit: } v_{\min} = \sqrt{rg \left[\frac{\tan \theta - \mu_s}{1 + \mu_s \tan \theta} \right]}$$

$$\text{iii. } v_{\max} = \sqrt{rg \tan \theta} \quad (\text{in absence of friction})$$

12. Height of inclined road: $h = l \sin \theta$

13. Conical Pendulum:

- i. Angular velocity of the bob of conical pendulum, $\omega = \sqrt{\frac{g}{L \cos \theta}}$
- ii. Period of conical pendulum, $T = 2\pi \sqrt{\frac{L \cos \theta}{g}}$

14. For mass tied to string:

- i. Minimum velocity at lowest point to complete V.C.M: $v_L = \sqrt{5rg}$
- ii. Minimum velocity at highest point to complete V.C.M: $v_H = \sqrt{rg}$
- iii. Minimum velocity at midway point to complete in V.C.M: $v_M = \sqrt{3rg}$
- iv. Tension at highest point in V.C.M:

$$T_H = \frac{mv_H^2}{r} - mg$$
- v. Tension at midway point in V.C.M: $T_M = \frac{mv_M^2}{r}$
- vi. Tension at lowest point in V.C.M:

$$T_L = \frac{mv_L^2}{r} + mg$$
- vii. Difference between tension at lower most and uppermost point: $T_L - T_H = 6mg$

15. Moment of Inertia: $I = \sum_{i=1}^n m_i r_i^2 = \int dm r^2$ 16. Radius of gyration: $K = \sqrt{\frac{I}{M}}$

17. Kinetic energy:

- i. $K.E = \frac{1}{2} I \omega^2 = \frac{1}{2} I (2\pi n)^2$
- ii. $K.E_{\text{translational}} = \frac{1}{2} M v^2$
- iii. $K.E_{\text{rolling}} = \frac{1}{2} [Mv^2 + I\omega^2] = \frac{1}{2} M v^2 \left[1 + \frac{K^2}{R^2} \right]$

18. Velocity of rolling body: $v = \sqrt{\frac{2gh}{1 + \frac{K^2}{R^2}}}$ 19. Acceleration of rolling body: $a = \frac{g \sin \theta}{1 + \frac{K^2}{R^2}}$

Page no. **466** to **47** are purposely left blank.

To see complete chapter buy **Target Notes** or **Target E-Notes**

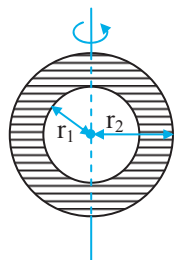
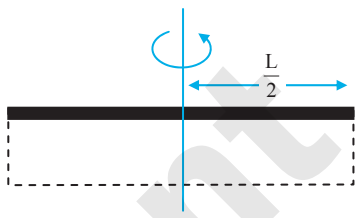
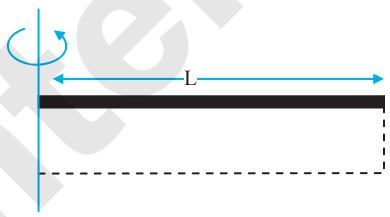
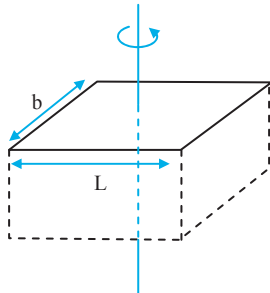

Uniform symmetric spherical shell	Central	$I = \frac{2}{5} M \frac{(r_2^5 - r_1^5)}{(r_2^3 - r_1^3)}$	
Thin uniform rod or rectangular plate	Perpendicular to length and passing through centre	$I = \frac{1}{12} ML^2$	
Thin uniform rod or rectangular plate	Perpendicular to length and about one end	$I = \frac{1}{3} ML^2$	
Uniform plate or rectangular parallelepiped	Central	$I = \frac{1}{12} M(L^2 + b^2)$	

EXERCISE

Theory Questions for Practice

1.2 Characteristics of Circular Motion

1. State characteristics of circular motion.

[2 Marks]

Ans: Refer Q.3.

2. Mention the expression for tangential velocity (in vector form) when a body is performing circular motion.

[1 Mark]

Ans: Refer Q.6(i).

3. Explain right hand thumb rule.

[1 Mark]

Ans: Refer Q.7

4. State relation of angular velocity with periodic time and frequency?

[1 Mark]

Ans: Refer Q.8(i).

5. With the help of an example, explain the term uniform circular motion. Also, define uniform circular motion.

[2 Marks]

Ans: Refer Q.9

6. Difference between centripetal force and centrifugal force.

[2 Marks]

Ans: Refer Q.17

1.3 Applications of Uniform Circular Motion

7. Obtain an expression for maximum possible speed for a vehicle to move on horizontal unbanked road.

[3 Marks]

Ans: Refer Q.28

8. Derive an expression for angle at which the two wheeler rider has to lean with the vertical while driving along an unbanked circular road.

[3 Marks]

Ans: Refer Q.29

9. What do you do if your vehicle is trapped on a slippery or a sandy road? What is the physics involved?

[1 Mark]

Ans: Refer Q.30(IV)

Page no. **49** is purposely left blank.

To see complete chapter buy **Target Notes** or **Target E-Notes**



1.8 Angular Momentum or Moment of Linear Momentum

32. Obtain an expression that relates angular momentum with the angular velocity of a rigid body. [2 Marks]

Ans: Refer Q.112

1.9 Expression for Torque in Terms of Moment of Inertia

33. Obtain an expression for torque acting on a body rotating with uniform angular acceleration. [3 Marks] [July 16]

Ans: Refer Q.114

1.10 Conservation of Angular Momentum

34. State law of conservation of angular momentum. [1 Mark] [July 22]

Ans: Refer Q.118 (Statement Only)

35. State and prove: law of conservation of angular momentum. [3 Marks] [Oct 15]

OR

State and prove principle of conservation of angular momentum. [2 Marks] [Feb 23]

Ans: Refer Q.118 (Principle and Proof only)

1.11 Rolling Motion

36. Obtain an expression for total kinetic energy of a rolling body in the form $\frac{1}{2}MV^2\left[1+\frac{K^2}{R^2}\right]$. [2 Marks] [Mar 16]

Ans: Refer Q.127

37. Obtain expressions for the acceleration of a rigid body along the an incline and the speed after falling through a certain vertical distance. [3 Marks]

Ans: Refer Q.130

Numericals for Practice

1.2 Characteristics of Circular Motion

1. A body of mass 1 kg is tied to a string and revolved in a horizontal circle of radius 1 m. Calculate the maximum number of revolutions per minute, so that the string does not break. Breaking tension of the string is 9.86 N. [2 Marks]

Ans: 30

2. Find the angular displacement of a particle moving on a circle with angular velocity $(2\pi/3)$ rad/s in 15 s. [2 Marks]

Ans: 10π rad

3. A 0.5 kg mass is rotated in a horizontal circle of radius 20 cm. Calculate the centripetal force acting on it, if its angular speed of rotation is 0.6 rad/s. [2 Marks]

Ans: 0.036 N

4. A particle performing UCM changes its angular velocity from 70 r.p.m to 130 r.p.m in 18 s. Find the angular acceleration of the particle. [2 Marks]

Ans: 0.349 rad/s^2

5. A fly wheel rotating at 420 r.p.m. slows down at a constant rate of 2 rad/s^2 . What time is required to stop the fly wheel? [2 Marks]

Ans: 22 s

6. The earth moves round the sun in an almost circular orbit of radius $1.5 \times 10^{11} \text{ m}$ with constant angular speed. Calculate its

- angular velocity
- linear velocity
- centripetal acceleration

[Given: 1 year = 3.156×10^7 sec,

Mass of earth = $5.98 \times 10^{24} \text{ kg}$]

[3 Marks]

- Ans: i. $1.99 \times 10^{-7} \text{ rad/s}$
ii. $2.985 \times 10^4 \text{ m/s}$
iii. $5.941 \times 10^{-3} \text{ m/s}^2$

7. A string breaks under a tension of 10 kg-wt. If the string is used to revolve a body of mass 12 g in a horizontal circle of radius 50 cm, what is the frequency of revolution and linear speed with which the body can be revolved?

[$g = 9.8 \text{ m/s}^2$]

[3 Marks]

Ans: 20.34 rev/s, 63.9 m/s

8. The tangential acceleration of the tip of a blade is 47.13 m/s^2 and its centripetal acceleration is 473.9 m/s^2 . Find the value of linear acceleration of the tip of the blade. [2 Marks]

Ans: $4.762 \times 10^2 \text{ m/s}^2$

9. A coin is placed on a revolving disc which revolves at 60 r.p.m. It does not slip-off when it is at 15 cm from the axis of rotation. What should be the distance of the coin from the axis of rotation so that it does not slip-off, when the speed of the revolving disc is changed to 75 r.p.m? [2 Marks]

Ans: 9.6 cm

Page no. **5511** to **553** are purposely left blank.

To see complete chapter buy **Target Notes** or **Target E-Notes**



1.11 Rolling Motion

55. A rigid body starts from rest and then rolls down a plane inclined at 11° to the horizontal. If the ratio of the radius of gyration to the radius of the body is 0.6 and if g is 10 m/s^2 . What is the linear acceleration of the body while rolling down the plane? [2 Marks]

Ans: 1.4 m/s^2

56. A solid cylinder rolls down an inclined plane from a height of 0.9 m. What is the linear velocity acquired by the cylinder when it reaches the bottom of the plane? [2 Marks]

Ans: 3.43 m s^{-1}

57. A body of mass 2.25 kg rolls on a horizontal surface with a linear velocity of 1.2 m/s. If the total kinetic energy of the rolling motion of the ring is 15 J, what is the rotational K.E. of the body. [2 Marks]

Ans: 13.38 J

58. A ball has a mass of 3.8 kg, a moment of inertia of $1.4 \times 10^{-2} \text{ kg m}^2$ and a radius of 0.12 m. What is its total energy if it rolls without slipping at a linear speed of 3.5 m/s? [2 Marks]

Ans: 29.23 J

59. A hollow cylinder rolls on a horizontal surface with a translational speed of 2 m/s. If its mass is 4 kg and radius of gyration is equal to its radius, then what is the total energy of the rolling motion? [2 Marks]

Ans: 16 J

Scan the given Q. R. Code in *Quill - The Padhai App* to view the solutions of the Numericals for practice.



MULTIPLE CHOICE QUESTIONS

[1 Mark Each]

1. A particle rotates in U.C.M. with tangential velocity 'v' along a horizontal circle of diameter 'D'. Total angular displacement of the particle in time 't' is _____. [Mar 16]

- (A) vt (B) $\left(\frac{v}{D}\right) \cdot t$
 (C) $\frac{vt}{2D}$ (D) $\frac{2vt}{D}$

*2. When seen from below, the blades of a ceiling fan are seen to be revolving anticlockwise and their speed is decreasing. Select correct statement about the directions of its angular velocity and angular acceleration.

- (A) Angular velocity upwards, angular acceleration downwards.
 (B) Angular velocity downwards, angular acceleration upwards.
 (C) Both, angular velocity and angular acceleration, upwards.
 (D) Both, angular velocity and angular acceleration, downwards.

3. The bulging of earth at the equator and flattening at the poles is due to _____.

- (A) centripetal force
 (B) centrifugal force
 (C) gravitational force
 (D) electrostatic force

4. The magnitude of centripetal force cannot be expressed as

- (A) $mr\omega^2$ (B) $\frac{4\pi^2 mr}{T^2}$
 (C) $mv\omega$ (D) mv/ω

5. If a cycle wheel of radius 0.4 m completes one revolution in 2 seconds, then acceleration of the cycle is _____.

- (A) $0.4 \pi \text{ m/s}^2$ (B) $0.4 \pi^2 \text{ m/s}^2$
 (C) $\frac{\pi^2}{0.4} \text{ m/s}^2$ (D) $\frac{0.4}{\pi^2} \text{ m/s}^2$

6. A body of mass 'm' performs uniform circular motion along a circular path of radius 'r' with velocity 'v'. If its angular momentum is L, then the centripetal force acting on it is _____. [July 17]

- (A) $\frac{mL^2}{r^3}$ (B) $\frac{L^2}{mr}$
 (C) $\frac{L^2}{mr^2}$ (D) $\frac{L^2}{mr^3}$

7. In rotational motion of a rigid body, all particles move with _____. [Feb 20]

- (A) same linear velocity and same angular velocity
 (B) same linear velocity and different angular velocity
 (C) different linear velocities and same angular velocities
 (D) different linear velocities and different angular velocities

Page no. **555** to **576** are purposely left blank.

To see complete chapter buy **Target Notes** or **Target E-Notes**



ANSWERS TO MULTIPLE CHOICE QUESTIONS

1. (D) 2. (B) 3. (B) 4. (D)
 5. (B) 6. (D) 7. (C) 8. (C)
 9. (C) 10. (A) 11. (B) 12. (A)
 13. (C) 14. (D) 15. (B) 16. (A)
 17. (D) 18. (C) 19. (A) 20. (B)
 21. (C) 22. (B) 23. (A) 24. (A)
 25. (B) 26. (B) 27. (B) 28. (A)
 29. (A) 30. (B) 31. (B) 32. (C)
 33. (A) 34. (A) 35. (C) 36. (A)
 37. (D) 38. (C) 39. (D) 40. (A)
 41. (D) 42. (B) 43. (C) 44. (C)
 45. (C) 46. (B) 47. (C) 48. (A)
 49. (C) 50. (B)

HINTS TO MULTIPLE CHOICE QUESTIONS

1. $\theta = \frac{s}{r}$ but $s = vt$ and $r = \frac{D}{2}$
 $\therefore \theta = \frac{2vt}{D}$
6. $F_{CP} = \frac{mv^2}{r}$
 Multiplying and dividing the equation by mr^2 ,
 we get, $F_{CP} = \frac{m^2v^2r^2}{mr^3}$
 $\therefore F_{CP} = \frac{L^2}{mr^3} \dots (\because L = mvr)$
9. $v_{\max} = \sqrt{5rg} = \sqrt{5} \cdot \sqrt{rg} = 5\sqrt{5}$
 $\dots (\text{since, } v_{\min} = \sqrt{rg})$
 $T_L - T_H = 6mg = 6 \times 1 \times 10 = 60 \text{ N}$
17. $K = \sqrt{\frac{I}{M}}$
 Using theorem of parallel axes,
 $I = I_o + Mh^2 = \frac{2}{5}Mr^2 + Mh^2$
 $\therefore r = \sqrt{\frac{M\left(\frac{2}{5}r^2 + h^2\right)}{M}}$
 $\therefore r^2 = \frac{2}{5}r^2 + h^2$
 $\therefore h = \frac{3}{5}r^2 \Rightarrow h = \sqrt{\frac{3}{5}}r = \sqrt{0.6}r$
36. $E = \frac{1}{2}I\omega^2$
 $\therefore 2E = (I\omega)\omega$
 $\therefore \frac{2E}{\omega} = L$

38. Linear density $\rho = \frac{M}{L}$
 $\therefore M = \rho L$
 Wire of length L is bent into a coil of radius R
 $\therefore R = \frac{L}{2\pi}$
 M.I. of coil through any tangent in the plane of the coil = $\frac{3}{2}MR^2 = \frac{3}{2}(\rho L) \times \left(\frac{L}{2\pi}\right)^2 = \frac{3\rho L^3}{8\pi^2}$

40. $I_c = MR^2 = 0.25 \times 0.5^2 = 0.0625 \text{ kgm}^2$

42.

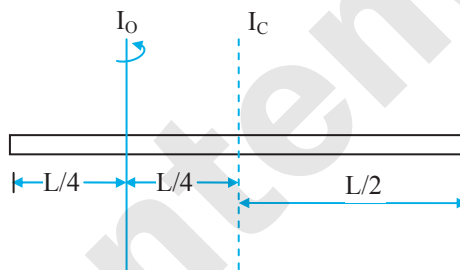

From parallel axis theorem,

$$I_o = I_c + Mh^2 = \frac{ML^2}{12} + M\left(\frac{L}{4}\right)^2 = \frac{ML^2}{12} + \frac{ML^2}{16} = \frac{7ML^2}{48}$$

45. $K.E_1 = K.E_2$
 $\therefore \frac{1}{2}I_1\omega_1^2 = \frac{1}{2}mv^2$
 $\therefore \frac{5 \times 36}{2} = \frac{20v^2}{2}$
 $\therefore 90 = 10v^2$
 $\therefore v = 3 \text{ m/s}$
46. **Case I:** $\frac{1}{2}MR^2 = MK_1^2$
 $\therefore K_1^2 = \frac{R^2}{2}$
Case II: $\frac{5}{4}MR^2 = MK_2^2$
 $\frac{5}{4}M(2K_1^2) = MK_2^2$
 $\therefore K_2^2 = \frac{5}{2}K_1^2 = \frac{5}{2} \times 2.5 = 2.5 \times 2.5$
 $\therefore K_2 = 2.5 \text{ m}$
48. For hollow cylinder, $\frac{K^2}{R^2} = 1$
 $\therefore \frac{K^2}{R^2} : 1 : \frac{1+K^2}{R^2} = 1:1:2$



COMPETITIVE CORNER

1. A thin circular plate of mass M and radius R has its density varying as $\rho(r) = \rho_0 r$ with ρ_0 as constant and r is the distance from its center. The moment of Inertia of the circular plate about an axis perpendicular to the plate and passing through its edge is $I = aMR^2$. The value of the coefficient a is: **[JEE (Main) 2019]**

- (A) $\frac{1}{2}$ (B) $\frac{3}{5}$
 (C) $\frac{8}{5}$ (D) $\frac{3}{2}$

Hint: $M = \int_0^R \rho_0 r \times (2\pi r dr)$

$\therefore M = \frac{2\pi\rho_0 R^3}{3}$

$I_C = \int_0^R \rho_0 r \times (2\pi r dr) \times r^2$

$\therefore I_C = \frac{2\pi\rho_0 R^5}{5}$

By parallel axis theorem, $I = I_C + MR^2$

$\therefore I = \frac{\rho_0 2\pi R^5}{5} + \frac{\rho_0 \times 2\pi R^3}{3} \times R^2$
 $= \rho_0 2\pi R^5 \left(\frac{1}{5} + \frac{1}{3} \right) = \frac{16\pi\rho_0 R^5}{15}$

$\therefore I = \frac{8}{5} \left(\frac{2}{3} \pi\rho_0 R^3 \right) R^2 = \frac{8}{5} MR^2$

$\therefore a = \frac{8}{5} \dots (\because I = aMR^2)$

2. A block of mass 10 kg is in contact against the inner wall of a hollow cylindrical drum of radius 1 m . The coefficient of friction between the block and the inner wall of the cylinder is 0.1 . The minimum angular velocity needed for the cylinder to keep the block stationary when the cylinder is vertical and rotating about its axis, will be ($g = 10 \text{ m/s}^2$) **[NEET (UG) 2019]**

- (A) 10 rad/s (B) $10\pi \text{ rad/s}$
 (C) $\sqrt{10} \text{ rad/s}$ (D) $\frac{10}{2\pi} \text{ rad/s}$

Hint:

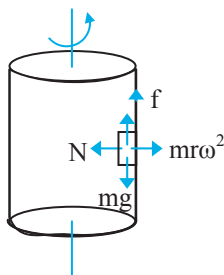

For equilibrium of the block, $F \geq mg$

$\therefore \mu N \geq mg$
 $\therefore \mu(mr\omega^2) \geq mg \quad (\because N = mr\omega^2)$

$\therefore \omega^2 \geq \frac{g}{\mu r} \Rightarrow \omega \geq \sqrt{\frac{g}{\mu r}}$

$\therefore \omega_{\min} = \sqrt{\frac{g}{\mu r}} = \sqrt{\frac{10}{0.1 \times 1}} = 10 \text{ rad/s}$

3. A solid cylinder of mass 2 kg and radius 50 cm rolls up an inclined plane of angle of inclination 30° . The centre of mass of the cylinder has speed of 4 m/s . The distance travelled by the cylinder on the inclined surface will be, [take $g = 10 \text{ m/s}^2$] **[NEET (Odisha) 2019]**

- (A) 2.4 m (B) 2.2 m
 (C) 1.6 m (D) 1.2 m

Hint:

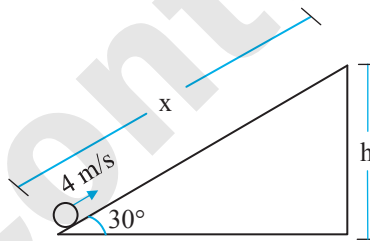

$v = \sqrt{\frac{2gh}{1 + \frac{K^2}{R^2}}}$

$\therefore 4^2 = \frac{2 \times 10 \times h}{1 + \frac{1}{2}} \dots \left[\because \text{For solid cylinders } \frac{K^2}{R^2} = \frac{1}{2} \right]$

$\therefore 2 \times 10 \times h = 16 \times \frac{3}{2}$

$\therefore h = \frac{24}{20} = 1.2 \text{ m}$

Now, $\sin \theta = \frac{h}{x}$

$\therefore \sin 30^\circ = \frac{1.2}{x}$

$\therefore x = \frac{1.2}{1/2} = 2.4 \text{ m}$

4. When 'W' joule of work is done on a flywheel, its frequency of rotation increases from ' n_1 ' Hz to ' n_2 ' Hz. The M.I. of the flywheel about its axis of rotation is given by **[MHT CET 2019]**

- (A) $\frac{W}{2\pi^2(n_2^2 - n_1^2)}$ (B) $\frac{W}{4\pi^2(n_2^2 + n_1^2)}$
 (C) $\frac{W}{4\pi^2(n_2^2 - n_1^2)}$ (D) $\frac{W}{2\pi^2(n_2^2 + n_1^2)}$

Page no. **660 to 61** is purposely left blank.

To see complete chapter buy **Target Notes** or **Target E-Notes**



Hint: M.I of a circular disc = $\frac{MR^2}{2}$

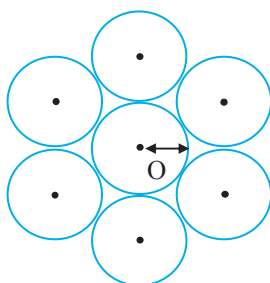

Using parallel axis theorem, M.I. about origin
 $I = I_{cm} + 6I$

where, $I_{cm} = M \cdot I$ of the central disc
 $I' = m \cdot I$ of the each disc about the given axis.

$$\begin{aligned} \therefore I &= \frac{MR^2}{2} + 6(I_{cm} + mD^2) \\ &= \frac{MR^2}{2} + 6\left(\frac{MR^2}{2} + 4mR^2\right) \quad \dots(\because D = 2R) \\ &= \frac{MR^2}{2} + 6\left(\frac{MR^2 + 8mR^2}{2}\right) \\ &= \frac{55MR^2}{2} \end{aligned}$$

Time: 1 Hour 30 Min

TOPIC TEST

Total Marks: 25

SECTION A

Q.1. Select and write the correct answer:

[04]

- i. For a particle performing vertical circular motion, the difference in tensions in the string at lowest and highest points is
 (A) mg (B) 3 mg (C) 6 mg (D) 12 mg
- ii. The potential energy at the highest point for a particle of mass m performing vertical circular motion in a circle of radius r is _____.
 (A) 2 mgr (B) 3mgr (C) 0 (D) 4 mgr
- iii. A fly wheel rotating about a fixed axis has a kinetic energy of 360 J, when its angular speed is 30 rad s^{-1} . What is the moment of inertia?
 (A) 0.4 kg m^2 (B) 0.6 kg m^2 (C) 0.8 kg m^2 (D) 1.0 kg m^2
- iv. A wheel of mass 10 kg has a moment of inertia of 160 kg m^2 about its own axis. The radius of gyration will be
 (A) 10 m (B) 8 m (C) 6 m (D) 4 m

Q.2. Answer the following:

[03]

- i. About which axis would a uniform cube have its minimum moment of inertia?
- ii. State right hand thumb rule to find the direction of angular displacement.
- iii. A car of mass 1500 kg rounds a curve of radius 250m at 90 km/hour. Calculate the centripetal force acting on it.

SECTION B

Attempt any Four:

[08]

- Q.3. A racing car completes 5 rounds of a circular track in 2 minutes. Find the radius of the track if the car has uniform centripetal acceleration of $\pi^2 \text{ m/s}^2$.
- Q.4. Distinguish between centripetal force and centrifugal force.
- Q.5. State the following terms:
 i. Simple pendulum ii. Conical pendulum
- Q.6. A flat curve on a highway has a radius of curvature 200 m. A car goes around a curve at a speed of 32 m/s. What is the minimum value of coefficient of friction that will prevent the car from sliding? ($g = 9.8 \text{ m/s}^2$)



- Q.7. Draw a diagram to represent conical pendulum in a non-inertial frame of reference and state the equation of centrifugal force on the bob.
- Q.8. What is meant by mass tied to a rod? How is it different from mass tied to a string?

SECTION C

Attempt any Two:

[06]

- Q.9. Explain the expression for upper limit on the speed when vehicle is at the top of a convex overbridge.
- Q.10. Derive an expression for kinetic energy of a rotating body.
- Q.11. A solid cylinder of mass 20 kg rotates about its axis with angular speed 100 rad s^{-1} . The radius of the cylinder is 0.25 m. What is the kinetic energy associated with the rotation of the cylinder? What is the magnitude of angular momentum of the cylinder about its axis?

SECTION D

Attempt any One:

[04]

- Q.12. State and prove theorem of parallel axes about moment of inertia.
- Q.13. i. What will be the duration of the day, if the earth suddenly shrinks to $1/27$ of its original volume, mass remaining unchanged?
ii. Prove the principle of conservation of angular momentum.

Scan the given Q. R. Code in *Quill - The Padhai App* to view the solutions of the Topic Test.



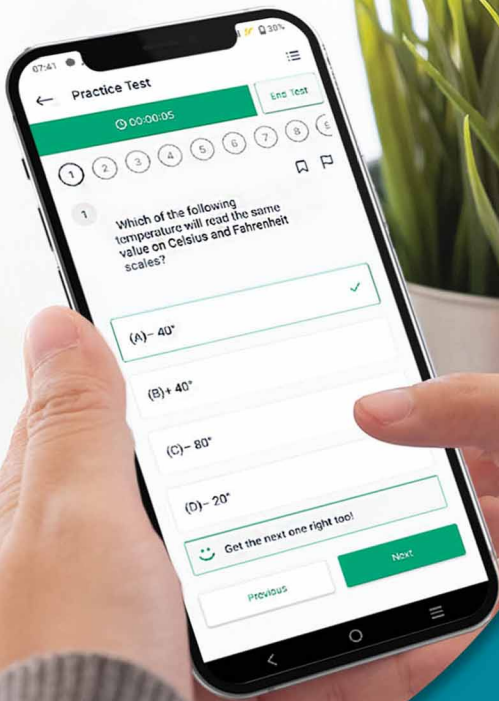

Give your XIIth exam preparation the **TECHNOLOGY BOOST!**

Practice more than **4,500 MCQs**

Use Coupon Code **QUILLPADHAI2023**

Also available for Xth, XIth, MHT-CET, NEET & JEE

- Practice chapter-wise & full syllabus MCQs in test format
- Get instant verification of your answer
- Detailed analysis of every test on completion
- Option to save questions for future reference



Scan QR Code to download the app

Visit our website to know more about our range of books for **Xth, XIth, MHT-CET, NEET & JEE**

Visit Our Website

Target Publications® Pvt. Ltd.
Transforming lives through learning.

Address:
B2, 9th Floor, Ashar, Road No. 16/Z,
Wagle Industrial Estate, Thane (W)- 400604

Tel: 88799 39712 / 13 / 14 / 15

Website: www.targetpublications.org

Email: mail@targetpublications.org



Explore our range of **STD. XII Sci. Books**

