

**SAMPLE CONTENT**

# 10 PRACTICE PAPER SET



IN ACCORDANCE WITH THE LATEST CUET (UG) PAPER CONDUCTED BY

# CUET (UG)

Common University Entrance Test

# PHYSICS

Section - II CODE: 322

## Features:

- ▶ Based on the notified syllabus prescribed by NTA
- ▶ Smart keys provided to crack questions efficiently
- ▶ Includes solved CUET (UG) 2022 question paper
- ▶ Covers a variety of questions:
  - Passage / Case - Study Based Questions
  - Statement Based Questions
  - Match the Columns

**Target** Publications® Pvt. Ltd.

# 10 PRACTICE PAPER SET

**CUET (UG)**

(Common University Entrance Test)

## PHYSICS

### SALIENT FEATURES:

- ☞ Created as per the syllabus prescribed by NTA
- ☞ In accordance with the latest CUET (UG) Paper conducted by NTA
- ☞ Set of 10 full length Question Papers with Answers and Solutions
- ☞ Exhaustive coverage of all types of questions based on the latest CUET (UG) question paper
- ☞ **Smart Key** provided to crack questions efficiently
- ☞ Includes **Solved Question Paper** of CUET (UG) 2022, 6<sup>th</sup> August (Slot - 2)

Printed at: **Print to Print**, Mumbai

© Target Publications Pvt. Ltd.

No part of this book may be reproduced or transmitted in any form or by any means, C.D. ROM/Audio Video Cassettes or electronic, mechanical including photocopying; recording or by any information storage and retrieval system without permission in writing from the Publisher.

## PREFACE

The Common University Entrance Test, CUET (UG) is a crucial milestone for students as they progress towards their undergraduate education. It is the sole opportunity for them to gain admission into premier undergraduate institutions and courses after the completion of Class XII.

Target Publications, with more than a decade of experience and expertise in the domain of competitive examination, offers ‘**CUET (UG) 10 Practice Paper Set**’ – Physics for CUET (UG) aspirants, which is a meticulously designed book to assess the threshold of knowledge imbibed by students.

This book charts out a compilation of 10 Practice Papers aimed at students appearing for the CUET (UG) examination. Every question paper in this book has been created in line with syllabus prescribed by NTA for CUET (UG) Physics.

Each paper covers various question types (*Passage/Case-Study Based Questions, Match the Columns, Statement Based Questions*) based on CUET (UG) - 2022 question paper and touches upon all the conceptual nodes of Physics. The questions throughout this book are specifically curated by our expert authors with an astute attention to detail. The core objective of this book is to gauge the student’s preparedness to appear for CUET (UG) examination.

To aid students, **Solutions** are provided as deemed necessary. **Smart Keys** are provided selectively to encourage cracking a question efficiently by lateral thinking. **Question paper of CUET (UG) 2022** [6<sup>th</sup> August, 2022 (Slot - 2)] is provided along with solution to offer students a glimpse of the complexity of questions asked in entrance examination. The paper has been split topic wise to let the students know which of the topics were more relevant in the latest examination.

Apart from mastery on the subject content, we hope that this book will also help students to achieve objectives such as time-management and develop their ability to utilize the paper-pattern format (choice of questions to attempt) to their advantage in order to maximize their scores.

*We hope that the book helps the learners as we have envisioned.*

Publisher

**Edition:** First

The journey to create a complete book is strewn with triumphs, failures and near misses. If you think we’ve nearly missed something or want to applaud us for our triumphs, we’d love to hear from you. Please write to us on: [mail@targetpublications.org](mailto:mail@targetpublications.org)

---

### Disclaimer

This reference book is based on the CUET (UG) official syllabus prescribed by National Testing Agency (NTA). We the publishers are making this reference book which constitutes as fair use of textual contents which are transformed by adding and elaborating, with a view to simplify the same to enable the students to understand, memorize and reproduce the same in examinations.

Every care has been taken in the publication of this reference book by the Authors while creating the contents. The Authors and the Publishers shall not be responsible for any loss or damages caused to any person on account of errors or omissions which might have crept in or disagreement of any third party on the point of view expressed in the reference book.

© reserved with the Publisher for all the contents created by our Authors.

No copyright is claimed in the textual contents which are presented as part of fair dealing with a view to provide best supplementary study material for the benefit of students.

---

## Syllabus for CUET (UG) - Physics

### Unit I: Electrostatics

Electric charges and their conservation. Coulomb's law – force between two point charges, forces between multiple charges; superposition principle, and continuous charge distribution.

Electric field, electric field due to a point charge, electric field lines; electric dipole, electric field due to a dipole; torque on a dipole in a uniform electric field.

Electric flux, statement of Gauss's theorem and its applications to find field due to infinitely long straight wire, uniformly charged infinite plane sheet, and uniformly charged thin spherical shell (field inside and outside).

Electric potential, potential difference, electric potential due to a point charge, a dipole and system of charges; equipotential surfaces, the electrical potential energy of a system of two point charges, and electric dipoles in an electrostatic field.

Conductors and insulators, free charges, and bound charges inside a conductor. Dielectrics and electric polarization, capacitors and capacitance, the combination of capacitors in series and in parallel, the capacitance of a parallel plate capacitor with and without dielectric medium between the plates, energy stored in a capacitor, Van de Graaff generator.

### Unit II: Current Electricity

Electric current, the flow of electric charges in a metallic conductor, drift velocity and mobility, and their relation with electric current; Ohm's law, electrical resistance, V-I characteristics (linear and non-linear), electrical energy and power, electrical resistivity and conductivity.

Carbon resistors, colour code for carbon resistors; series and parallel combinations of resistors; temperature dependence of resistance.

The internal resistance of a cell, potential difference, and emf of a cell, combination of cells in series and in parallel.

Kirchhoff's laws and simple applications. Wheatstone bridge, metre bridge.

Potentiometer – principle, and applications to measure potential difference, and for comparing emf of two cells; measurement of internal resistance of a cell.

### Unit III: Magnetic Effects of Current and Magnetism

Concept of the magnetic field, Oersted's experiment. Biot - Savart law and its application to current carrying circular loop.

Ampere's law and its applications to infinitely long straight wire, straight and toroidal solenoids. Force on a moving charge in uniform magnetic and electric fields. Cyclotron.

Force on a current-carrying conductor in a uniform magnetic field. The force between two parallel current-carrying conductors – definition of ampere. Torque experienced by a current loop in a magnetic field; moving coil galvanometer – its current sensitivity and conversion to ammeter and voltmeter.

Current loop as a magnetic dipole and its magnetic dipole moment. The magnetic dipole moment of a revolving electron. Magnetic field intensity due to a magnetic dipole (bar magnet) along its axis and perpendicular to its axis. Torque on a magnetic dipole (bar magnet) in a uniform magnetic field; bar magnet as an equivalent solenoid, magnetic field lines; Earth's magnetic field and magnetic elements.

Para-, dia- and ferromagnetic substances, with examples. Electromagnets and factors affecting their strengths. Permanent magnets.

### Unit IV: Electromagnetic Induction and Alternating Currents

Electromagnetic induction; Faraday's law, induced emf and current; Lenz's Law, Eddy currents. Self and mutual inductance.

Alternating currents, peak and rms value of alternating current/voltage; reactance and impedance; LC oscillations (qualitative treatment only), LCR series circuit, resonance; power in AC circuits, wattless current. AC generator and transformer.

### **Unit V: Electromagnetic Waves**

Need for displacement current. Electromagnetic waves and their characteristics (qualitative ideas only). Transverse nature of electromagnetic waves.

Electromagnetic spectrum (radio waves, microwaves, infrared, visible, ultraviolet, x-rays, gamma rays) including elementary facts about their uses.

### **Unit VI: Optics**

Reflection of light, spherical mirrors, mirror formula. Refraction of light, total internal reflection, and its applications, optical fibres, refraction at spherical surfaces, lenses, thin lens formula, lens maker's formula. Magnification, power of a lens, combination of thin lenses in contact combination of a lens and a mirror. Refraction and dispersion of light through a prism.

Scattering of light–blue colour of the sky and reddish appearance of the sun at sunrise and sunset.

Optical instruments: Human eye, image formation, and accommodation, correction of eye defects (myopia and hypermetropia) using lenses.

Microscopes and astronomical telescopes (reflecting and refracting) and their magnifying powers.

Wave optics: Wavefront and Huygens' principle, reflection, and refraction of plane wave at a plane surface using wavefronts.

Proof of laws of reflection and refraction using Huygens' principle.

Interference, Young's double hole experiment and expression for fringe width, coherent sources, and sustained interference of light.

Diffraction due to a single slit, width of central maximum.

Resolving the power of microscopes and astronomical telescopes. Polarisation, plane polarised light; Brewster's law, uses of plane polarised light and Polaroids.

### **Unit VII: Dual Nature of Matter and Radiation**

Photoelectric effect, Hertz and Lenard's observations; Einstein's photoelectric equation – particle nature of light.

Matter waves – wave nature of particles, de Broglie relation. Davisson-Germer experiment (experimental details should be omitted; only the conclusion should be explained.)

### **Unit VIII: Atoms and Nuclei**

Alpha - particle scattering experiment; Rutherford's model of atom; Bohr model, energy levels, hydrogen spectrum. Composition and size of nucleus, atomic masses, isotopes, isobars; isotones.

Radioactivity – alpha, beta, and gamma particles/rays, and their properties; radioactive decay law. Mass-energy relation, mass defect; binding energy per nucleon and its variation with mass number; nuclear fission and fusion.

### **Unit IX: Electronic Devices**

Energy bands in solids (qualitative ideas only), conductors, insulators, and semiconductors; semiconductor diode – I-V characteristics in forward and reverse bias, diode as a rectifier; I-V characteristics of LED, photodiode, solar cell, and Zener diode; Zener diode as a voltage regulator. Junction transistor, transistor action, characteristics of a transistor; transistor as an amplifier (common emitter configuration) and oscillator. Logic gates (OR, AND, NOT, NAND and NOR). Transistor as a switch.

### **Unit X: Communication Systems**

Elements of a communication system (block diagram only); bandwidth of signals (speech, TV, and digital data); bandwidth of transmission medium. Propagation of electromagnetic waves in the atmosphere, sky, and space wave propagation. Need for modulation. Production and detection of an amplitude-modulated wave.

## Broad features of CUET (UG)

Mode of Examination: Computer Based Test (CBT) mode						
Sections	Subjects/ Tests	Questions to be Attempted	Marks per Question	Total Marks	Question Type	Duration
<b>Section IA - Languages</b>	There are 13 different languages. Any of these languages may be chosen.	40 questions out of 50 in each language	5	200	<ul style="list-style-type: none"> <li>Language to be tested through Reading Comprehension based on different types of passages–Factual, Literary and Narrative, [Literary Aptitude and Vocabulary]</li> <li>MCQ Based Questions</li> </ul>	45 Minutes for each language
<b>Section IB - Languages</b>	There are 20 Languages. Any other language apart from those offered in Section I A may be chosen.					
<b>Section II - Domain</b>	There are 27 Domains specific Subjects being offered under this Section. A candidate may choose a maximum of Six Domains as desired by the applicable University/ Universities.	40 questions out of 50 in each subject	5	200	<ul style="list-style-type: none"> <li>Input text can be used for MCQ Based Questions</li> <li>MCQs based on syllabus given on NTA website</li> </ul>	45 Minutes for each Domain Specific Subjects
<b>Section III General Test</b>	For any such undergraduate programme/ programmes being offered by Universities where a General Test is being used for admission.	60 questions out of 75	5	300	<ul style="list-style-type: none"> <li>Input text can be used for MCQ Based Questions</li> <li>General Knowledge, Current Affairs, General Mental Ability, Numerical Ability, Quantitative Reasoning (Simple application of basic mathematical arithmetic/algebra geometry/mensuration /stat taught till Grade 8), Logical and Analytical Reasoning</li> </ul>	60 Minutes
<b>Note:</b>						
<ul style="list-style-type: none"> <li>One mark will be deducted for a wrong answer.</li> <li>Unanswered/Marked for Review will be given no mark (0).</li> </ul>						

Candidates are advised to visit the NTA CUET (UG) official website <https://cuet.samarth.ac.in/> for the latest updates regarding the Examination.

## Index

No.	Topic Name	Page No.
1	Practice Paper – 1	1
2	Practice Paper – 2	6
3	Practice Paper – 3	11
4	Practice Paper – 4	16
5	Practice Paper – 5	21
6	Practice Paper – 6	26
7	Practice Paper – 7	31
8	Practice Paper – 8	36
9	Practice Paper – 9	41
10	Practice Paper – 10	46
•	Solutions to Practice Papers	51
•	CUET (UG) - 2022 Question Paper with Solution 6 <sup>th</sup> August 2022 (Slot - 2)	79

Time: 45 minutes

Total Marks: 200

**Instructions:**

- Attempt any 40 out of the given 50 questions.
- Each question carries 5 marks.
- No mark will be given to unanswered/marked for review questions.
- Negative marking of 1 mark for a wrong answer.

1. A metal wire of circular cross-section has a resistance  $R_1$ . The wire is now stretched without breaking so that its length is doubled and the density is assumed to remain the same. If the resistance of the wire now becomes  $R_2$  then  $R_2 : R_1$  is  
 (A) 1 : 1 (B) 1 : 2  
 (C) 4 : 1 (D) 1 : 4
2. An electric dipole is put in north-south direction in a sphere filled with water. Which statements is/are correct?  
 (I) Electric flux is coming towards sphere.  
 (II) Electric flux is coming out of sphere.  
 (III) Electric flux entering into sphere and leaving the sphere are same.  
 (IV) Water does not permit electric flux to enter into sphere.  
 (A) Only (I) (B) (I) and (II)  
 (C) Only (III) (D) (I), (II) and (IV)
3. If a velocity has both perpendicular and parallel components while moving through a magnetic field, what is the path followed by a charged particle?  
 (A) Circular (B) Elliptical  
 (C) Linear (D) Helical
4. If a hole is made at the centre of a bar magnet, then its magnetic moment \_\_\_\_\_.  
 (A) increases (B) decreases  
 (C) does not change (D) vanishes
5. Two capacitors  $C_1$  and  $C_2$  are charged to 120 V and 200 V respectively. It is found that by connecting them together the potential on each one can be made zero. Then  
 (A)  $5C_1 = 3C_2$  (B)  $3C_1 = 5C_2$   
 (C)  $3C_1 + 5C_2 = 0$  (D)  $9C_1 = 4C_2$
6. The work function of metals is in the range of 2 eV to 5 eV. Find which of the following wavelength of light cannot be used for photoelectric effect. (Consider, Planck constant =  $4 \times 10^{-15}$  eVs, velocity of light =  $3 \times 10^8$  m/s)  
 (A) 510 nm (B) 650 nm  
 (C) 400 nm (D) 570 nm
7. A wire has a resistance of  $12 \Omega$ . It is bent in the form of a circle. The effective resistance between the two points on any diameter is equal to  
 (A)  $12 \Omega$  (B)  $6 \Omega$  (C)  $3 \Omega$  (D)  $24 \Omega$

8. Match List – I with List – II

List - I		List - II	
i.	$\alpha$ -decay	a.	Atomic number is unchanged
ii.	Positive $\beta$ -decay	b.	Atomic number decreases by 2
iii.	Negative $\beta$ -decay	c.	Atomic number increases by 1
iv.	$\gamma$ -decay	d.	Atomic number decreases by 1

- (A) (i – b), (ii – d), (iii – c), (iv – a)  
 (B) (i – a), (ii – c), (iii – b), (iv – d)  
 (C) (i – b), (ii – c), (iii – d), (iv – a)  
 (D) (i – a), (ii – d), (iii – b), (iv – c)
9. When an electromagnetic wave enters an ionised layer of earth's atmosphere present in ionosphere,  
 (A) the electron cloud will not oscillate in the electric field of the wave.  
 (B) the electron cloud will oscillate in the electric field of wave in the phase of sinusoidal electromagnetic wave  
 (C) the electron cloud will oscillate in the electric field of wave in the opposite phase of sinusoidal electromagnetic wave  
 (D) the electron cloud will oscillate in the electric field of wave with a phase retardation of  $90^\circ$  for a sinusoidal electromagnetic wave.
  10. Using Einstein's photoelectric equation, the graph between the K.E. (E) of photoelectrons emitted and the frequency of incident radiation ( $\nu$ ) is shown correctly in figure.

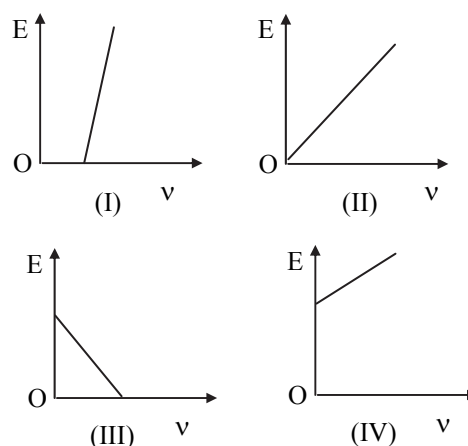

- (A) (II) (B) (I) (C) (IV) (D) (III)





11. In a semiconductor crystal if current flows due to breakage of crystal bonds, then semiconductor is called as

- (A) Acceptor  
(B) Donor  
(C) Intrinsic semiconductor  
(D) Extrinsic semiconductor

12. The volume of the nucleus is

- (A) directly proportional to the mass number.  
(B) directly proportional to the atomic number.  
(C) directly proportional to the number of neutrons.  
(D) directly proportional to the number of mesons.

13. Modulation factor or modulation index ( $m_a$ ) in AM is

- (A)  $\frac{A_{\max} - A_{\min}}{A_{\max} + A_{\min}}$       (B)  $\frac{A_{\max} + A_{\min}}{A_{\max} - A_{\min}}$   
(C)  $A_{\max} - A_{\min}$       (D)  $\frac{A_{\min} - A_{\max}}{A_{\max} + A_{\min}}$

14. **Assertion:** Electric dipole moment is a vector quantity.

**Reason:** The direction of electric dipole moment is from negative to positive charge.

- (A) Assertion is True, Reason is True; Reason is a correct explanation for Assertion.  
(B) Assertion is True, Reason is True; Reason is not a correct explanation for Assertion.  
(C) Assertion is True, Reason is False.  
(D) Assertion is False, Reason is False.

15. A step-down transformer is connected to 2400 volt line and 80 ampere of current is found to flow in output load. The ratio of the turns in primary and secondary coil is 20 : 1. If transformer efficiency is 100%, then the current flowing in primary coil will be

- (A) 1600 A      (B) 20 A  
(C) 4 A      (D) 1.5 A

16. When a magnetic dipole is placed along the direction of the field, the energy possessed by the dipole is

- (A) maximum.      (B) minimum.  
(C) zero.      (D) unaffected.

17. The variation of electrostatic potential with radial distance  $r$  from the centre of a positively charged metallic thin shell of radius  $R$  is given by the graph

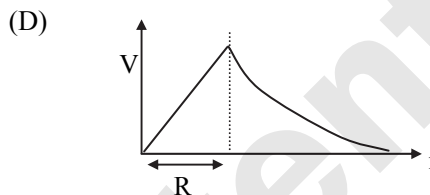
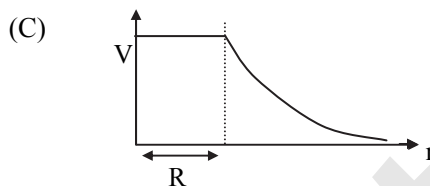
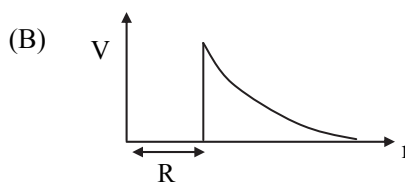
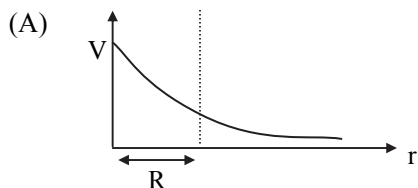

18. The maximum kinetic energy of protons in a cyclotron of radius 0.4 m in a magnetic field of 0.5 T is (mass of proton =  $1.67 \times 10^{-27}$  kg, charge of proton =  $1.6 \times 10^{-19}$  C)

- (A) 3 MeV      (B) 1.9 MeV  
(C) 5 MeV      (D) 4 MeV

19. Which of the following statements is/are correct for stopping potential in photoelectric emission?

- (I) It is directly proportional to maximum kinetic energy of emitted photoelectrons.  
(II) It is independent of intensity of incident light.  
(III) It is different for a metal exposed to light of different frequencies.  
(IV) It is independent of the nature of metal.  
(A) (I) and (II) only      (B) (II) and (IV)  
(C) (IV) only      (D) (I), (II) and (III)

20. The electric field intensity produced by the radiation coming from 100 W bulb at a 3 m distance is  $E$ . The electric field intensity produced by the radiations coming from 50 W bulb at the same distance is

- (A)  $\frac{E}{2}$       (B)  $2E$       (C)  $\frac{E}{\sqrt{2}}$       (D)  $\sqrt{2} E$

21. In the Bohr model of a hydrogen atom, the centripetal force is furnished by the coulomb attraction between the proton and the electron. If  $a_0$  is the radius of the ground state orbit,  $m$  is the mass and  $e$  is charge on the electron and  $\epsilon_0$  is the vacuum permittivity, the speed of the electron is

- (A) 0      (B)  $\frac{e}{\sqrt{\epsilon_0 a_0 m}}$   
(C)  $\frac{e}{\sqrt{4\pi\epsilon_0 a_0 m}}$       (D)  $\sqrt{\frac{4\pi\epsilon_0 a_0 m}{e}}$

Page no. **3** to **50** are purposely left blank.

To see complete chapter buy **Target Notes** or **Target E-Notes**

Practice Paper – 01

1. (C)

For a given wire, its resistance

$$R \propto \frac{l}{A}$$

$$\therefore R_1 \propto \frac{l_1}{A_1} = \frac{l_1}{4\pi r_1^2}$$

Wire is stretched such that  $l_2 = 2l_1$   
But density is unchanged.

$$\therefore \text{Density} = \frac{M}{V} = \frac{M}{4\pi r_1^2 l_1} = \frac{M}{4\pi r_2^2 l_2}$$

$$\Rightarrow r_2^2 = \frac{l_1 r_1^2}{l_2} = \frac{r_1^2}{2} \quad (\because l_2 = 2l_1)$$

$$\therefore r_2 = \frac{r_1}{\sqrt{2}}$$

$$\text{Now, } R_2 \propto \frac{l_2}{A_2} = \frac{l_2}{4\pi r_2^2} = \frac{2l_1}{4\pi (r_1^2/2)} = 4 \left( \frac{l_1}{4\pi r_1^2} \right)$$

$$\therefore R_2 : R_1 = 4 : 1$$

2. (C)

In electric dipole, the flux coming out from positive charge is equal to the flux coming in at negative charge i.e., total charge on sphere = 0. From Gauss' law, total flux passing through the sphere = 0.

3. (D)

Parallel component drags the particle to side and perpendicular component gives circular path. Hence the path is helical.

4. (C)

As its pole strength and length remains same.

5. (B)

To make potential zero net charge on two capacitors must be made zero. Hence, capacitors must be connected such that

$$Q = Q_1 - Q_2 = 0$$

$$\therefore C_1 V_1 - C_2 V_2 = 0$$

$$\therefore C_1 V_1 = C_2 V_2$$

$$\therefore 120 C_1 = 200 C_2$$

$$\therefore 3 C_1 = 5 C_2$$

6. (B)

For work function of 5 eV,

$$\lambda_{\min} = \frac{hc}{\phi} = \frac{4 \times 10^{-15} \times 3 \times 10^8}{5} = 240 \text{ nm,}$$

For work function of 2 eV,

$$\lambda_{\max} = \frac{hc}{\phi} = \frac{4 \times 10^{-15} \times 3 \times 10^8}{2} = 600 \text{ nm}$$

This means wavelength of 650 nm cannot be used.

7. (C)

$$R_{AB} = \frac{6}{2} = 3 \Omega$$

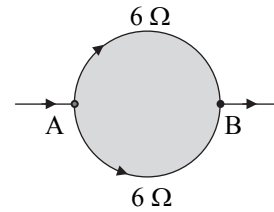

8. (A)

10. (B)

11. (C)

Semiconductors have covalent bonding. The current flows due to breaking of bond means a few electrons move from valence band to conduction band. It happens in a pure (intrinsic) semiconductor.

12. (A)

13. (A)

14. (A)

15. (C)

$$\frac{N_s}{N_p} = \frac{V_s}{V_p} \Rightarrow \frac{1}{20} = \frac{V_s}{2400} \Rightarrow V_s = 120 \text{ V}$$

For 100% efficiency  $V_s I_s = V_p I_p$

$$\therefore 120 \times 80 = 2400 I_p \Rightarrow I_p = 4 \text{ A}$$

16. (B)

17. (C)

For  $r < R$ ,  
 $V = \text{constant}$

For  $r \geq R$ ,  $V \propto \frac{1}{r}$

This is best depicted in graph (C).

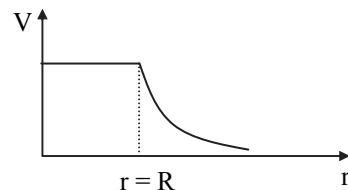
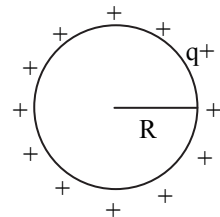

18. (B)

$$K = \frac{q^2 B^2 R^2}{2m} = \frac{(1.6 \times 10^{-19})^2 \times (0.5)^2 \times (4 \times 10^{-1})^2}{2 \times 1.67 \times 10^{-27}} = \frac{(1.6)^2 \times 10^{-38} \times 25 \times 10^{-2} \times 16 \times 10^{-2}}{2 \times 1.67 \times 10^{-27}} = \frac{1024 \times 10^{-42}}{3.34 \times 10^{-27}} = 306.58 \times 10^{-15} = 3.06 \times 10^{-13} \text{ J} = \frac{3.06 \times 10^{-13}}{1.6 \times 10^{-19}} \text{ eV} = 1.9 \times 10^6 \text{ eV}$$

$$\therefore K = 1.9 \text{ MeV.}$$



Page no. **53** to **78** are purposely left blank.

To see complete chapter buy **Target Notes** or **Target E-Notes**

# CUET (UG) - 2022 Question Paper

6<sup>th</sup> August 2022 (Slot - 2)

## Electric charges and fields

1. Electric field at the surface of a conducting shell of radius 'r' is measured as X. Electric field at a distance 3r from the centre of the shell is:

- (A)  $\frac{X}{3}$  (B)  $\frac{X}{6}$   
 (C)  $\frac{X}{9}$  (D) X

## Electrostatic potential and capacitance

2. The equivalent capacitance between the points A and B in the network given below is-

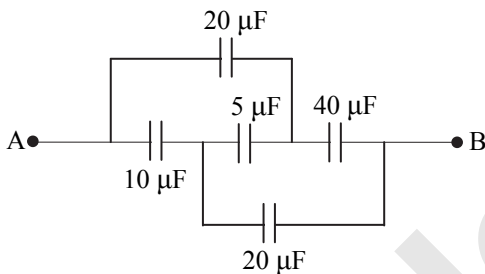

- (A)  $20 \mu\text{F}$  (B)  $\frac{20}{3} \mu\text{F}$   
 (C)  $\frac{40}{3} \mu\text{F}$  (D)  $10 \mu\text{F}$

3. A charge  $+10 \mu\text{C}$  is placed at (0 mm, 0 mm). Another charge  $-5 \mu\text{C}$  is moved from (3 mm, 0 mm) to (0 mm, 3 mm). Work done by the external agency is

- (A) 0 J (B)  $-150 \text{ J}$   
 (C)  $+150 \text{ J}$  (D)  $-300 \text{ J}$

## Current electricity

4. In a meter bridge, null point is found at a distance of 20 cm from the end A, then the resistance of  $10 \Omega$  is replaced by another resistance of  $20 \Omega$ , the null

- (A) 20 cm  
 (B) 30 cm  
 (C) 15 cm  
 (D) 40 cm

5. Changing current through 1V cell and through  $2 \Omega$  resistor respectively is

- (A) 2A, 1A  
 (B) 1A, 2A  
 (C) 2A, 2A  
 (D) 1A, 1A

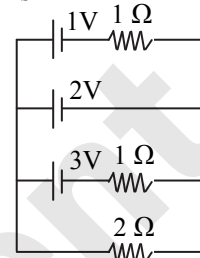

6. Correct temperature dependence of Resistivity of copper ( $\rho$ ) is shown by

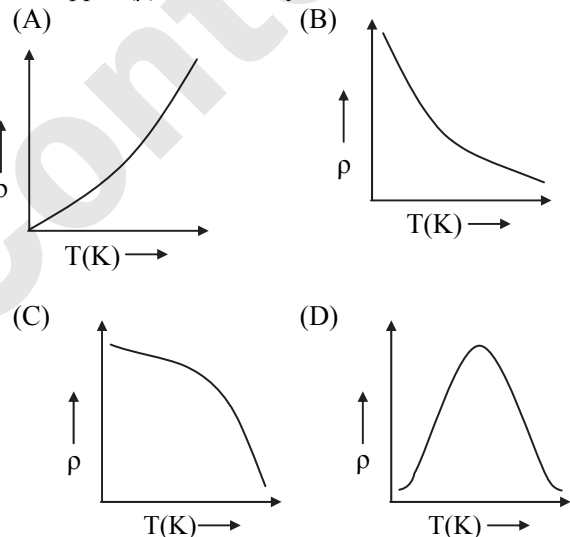

7. The mobility of charge carriers increases with  
 (A) increase in average collision time interval  
 (B) increase in the electric field  
 (C) increase in the mass of the charge carriers  
 (D) decrease in the charge of the mobile carriers

## Moving charges and magnetism

8. Consider an infinitely long conductor XY carrying current (x) A. A rectangular loop carrying current 2 A is placed parallel to it in the same plane. The two conductors are found to exert a force of  $1.8 \times 10^{-5} \text{ N/m}$ . Find the value of x.

- (A) 0.6 A  
 (B)  $3 \times 10^2 \text{ A}$   
 (C) 3A  
 (D)  $3 \times 10^{-2} \text{ A}$

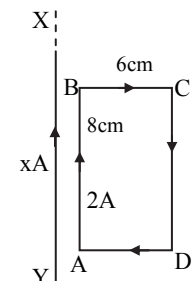

Page no. **80** to **84** are purposely left blank.

To see complete chapter buy **Target Notes** or **Target E-Notes**

# CUET (UG) - 2022

6<sup>th</sup> August 2022 (Slot - 2)

## Solution

1. (C)

For a conducting shell,

field at distance  $3r (> r) \propto \frac{1}{\text{distance}^2}$

$$\therefore \frac{E_{3r}}{E_r} = \frac{1/(3r)^2}{r^2} \Rightarrow E_{3r} = \frac{E_r}{9} = \frac{X}{9}$$

2. (A)

Given circuit is balanced Wheatstone bridge. Hence equivalent circuit becomes:

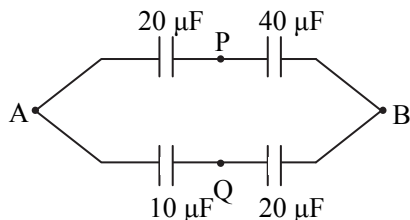

$$\therefore C_{APB} = \left( \frac{1}{20} + \frac{1}{40} \right)^{-1} = \frac{40}{3} \mu\text{F}$$

Similarly,

$$C_{AQB} = \left( \frac{1}{10} + \frac{1}{20} \right)^{-1} = \frac{20}{3} \mu\text{F}$$

$$\therefore C_{\text{total}} = C_{APB} + C_{AQB} = 20 \mu\text{F}$$

3. (A)

Since, potential due to  $+10 \mu\text{C}$  and  $-5 \mu\text{C}$  is the same at point A(3 mm, 0 mm), as to that of at point B(0 mm, 3 mm), no work will be done in moving charge  $-5 \mu\text{C}$  from A to B.

4. (D)

At null point condition,

$$\frac{R}{X} = \frac{l_1}{l_2} \Rightarrow l_2 = l_1 \times \frac{X}{R} = 20 \times \frac{20}{10} = 40 \text{ cm}$$

5. (D)

Let current through 1 volt battery be  $I_1$ , 2 volt battery be  $I_2$  and 3 volt battery be  $I_3$ .

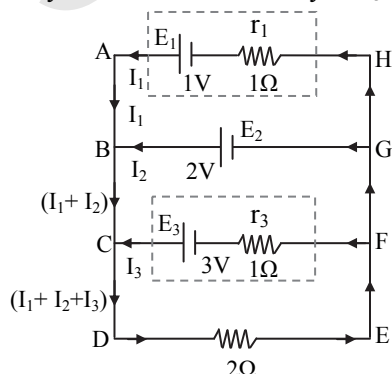

Applying Kirchhoff's voltage law (KVL) to loop ABCDEFGHA, we get,

$$2(I_1 + I_2 + I_3) + 1 I_1 = 1$$

$$\therefore 3I_1 + 2I_2 + 2I_3 = 1 \quad \dots\text{(i)}$$

Applying Kirchhoff's voltage law (KVL) to loop BCDEFGB, we get,

$$2(I_1 + I_2 + I_3) = 2$$

$$\therefore I_1 + I_2 + I_3 = 1 \quad \dots\text{(ii)}$$

$$\therefore I_2 = 1 - I_1 - I_3 \quad \dots\text{(iii)}$$

Applying Kirchhoff's voltage law (KVL) to loop CDEFC, we get,

$$2(I_1 + I_2 + I_3) + 1 I_3 = 3$$

$$2I_1 + 2I_2 + 3I_3 = 3 \quad \dots\text{(iv)}$$

Substituting for  $I_2$  into equation (iv) using equation (ii),

$$2I_1 + 2(1 - I_1 - I_3) + 3I_3 = 3$$

$$\therefore I_3 = 1 \text{ A}$$

Substituting for  $I_3$  and  $I_2$  into equation (i),

$$3I_1 + 2(1 - I_1 - 1) + 2(1) = 1$$

$$\therefore I_1 = -1 \text{ A}$$

Negative sign indicates that direction of flow of  $I_1$  is opposite to the direction assumed.

$$\therefore \text{Current through } 1 \text{ V cell, } I_1 = 1 \text{ A}$$

Also, current through  $2 \Omega$  resistor is,

$$I = I_1 + I_2 + I_3 = 1 \text{ A} \quad \dots\text{[From equation (ii)]}$$

6. (A)

The variation of resistivity of copper with temperature is parabolic in nature.

7. (A)

$$\text{Mobility, } \mu = \frac{e\tau}{m}$$

As relaxation time ( $\tau$ ) increases,  $\mu$  increases.

8. (\*)

In order to calculate, force exerted by conductors on each other, it is essential to know distance between the conductors. As the distance between conductor XY and AB is not mentioned in the question, given question cannot be solved.

Assuming the distance between conductor XY and AB as 4 cm, value of 'x' can be calculated as follows:

As, force acting on sides AD and BC is equal and opposite. Hence their combined force is zero.



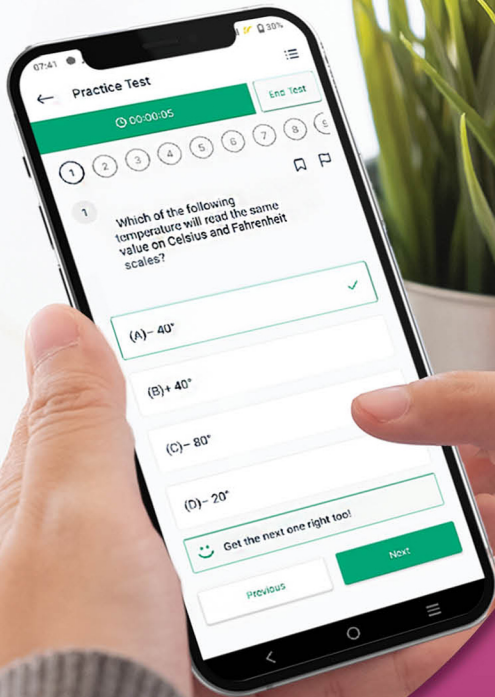

Give your CUET (UG) exam preparation the **TECHNOLOGY BOOST!**

Practice more than **5000 MCQs** of PCMB for just **₹999/-**

## Our books to help you crack the CUET (UG) Exam

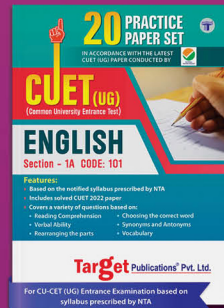
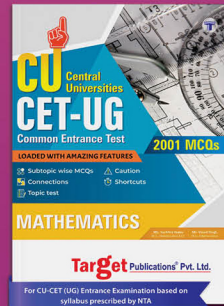
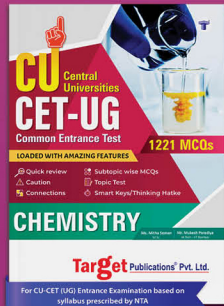
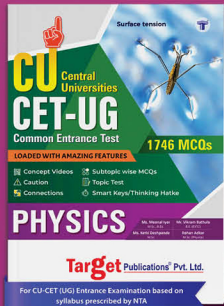

Scan QR Code to download the app

**Visit Our Website**

**Target Publications® Pvt. Ltd.**  
Transforming lives through learning.

**Address:**

2<sup>nd</sup> floor, Aroto Industrial Premises CHS,  
Above Surya Eye Hospital, 63-A, P. K. Road,  
Mulund (W), Mumbai 400 080

**Tel:** 88799 39712 / 13 / 14 / 15

**Website:** www.targetpublications.org

**Email:** mail@targetpublications.org

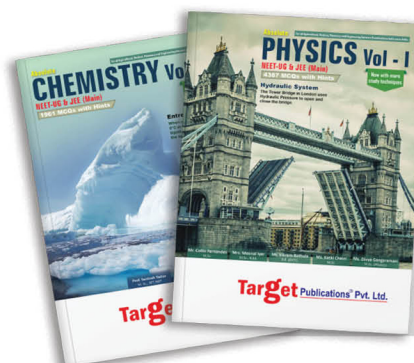

Explore our range of **NEET & JEE Books**

