

SAMPLE CONTENT

Absolute

NEET-UG & JEE (Main)

CHEMISTRY Vol - I

For all Medical and Engineering Entrance Examinations held across India.

2500+ MCQs with Hints



As per
latest syllabus
issued by
NMC

Entropy

When ice melts spontaneously above 0°C at 1 atm, entropy increases as the liquid state is more disordered than the solid state.

Prof. Santosh Yadav
M. Sc., SET, NET

Mr. Mukesh Paradiya
M.Tech - IIT Bombay

Ms. Trupti Kurkute
M.Sc. Chemistry, SET

Now with more
study techniques

Target Publications[®] Pvt. Ltd.

Absolute

NEET – UG & JEE (Main)

Chemistry Vol. I

Now with
more study
techniques

Updated as per latest syllabus for:

NEET (UG) 2024 issued by NMC on 6th October, 2023

JEE (Main) 2024 issued by NTA on 1st November, 2023

Salient Features

- ☞ Comprehensive theory for every topic.
- ☞ Subtopic-wise segregation of MCQs for efficient practice
- ☞ Exhaustive coverage of questions from previous NEET (UG), JEE (Main) and other competitive examinations **till year 2024:**
 - **2886** MCQs
 - **60** Numerical Value Type (NVT) questions
 - Solutions to the questions are provided for better understanding
- ☞ Includes **Smart Keys:** Multiple study techniques to enhance understanding and problem solving:
 - *Smart code* - *Smart tip* - *Caution*
 - *Remember This* - *Think out of the box*
- ☞ Includes relevant Solved Questions from:
 - NEET (UG) 2023 - JEE (Main) 2023 24th Jan (Shift - II)
 - NEET (UG) Manipur 2023
- ☞ Includes Question Paper and Answer Keys (Solutions through Q.R. code) of:
 - JEE (Main) 2024 31st January (Shift - I)
 - NEET (UG) 2024
- ☞ Topic Test provided in each chapter for self-assessment
- ☞ Q.R. codes provide:
 - Video links for boosting conceptual retention
 - Answers & Solutions to Topic Tests

Printed at: **India Printing Works**, Mumbai

© Target Publications Pvt. Ltd.

No part of this book may be reproduced or transmitted in any form or by any means, C.D. ROM/Audio Video Cassettes or electronic, mechanical including photocopying; recording or by any information storage and retrieval system without permission in writing from the Publisher.

Target's '**Absolute Chemistry Vol - I**' is a complete guidebook, extremely handy for preparation of various competitive exams like NEET (UG), JEE (Main). This edition provides an unmatched comprehensive amalgamation of theory with MCQs. The chapters are aligned with the latest syllabus for **NEET (UG) and JEE (Main) 2024** examinations. Although the alignment runs parallel to NCERT curriculum, the structure of the chapters prioritizes knowledge building of the students. The book provides the students with scientifically accurate context, several study techniques and skills required to excel in these examinations.

All the questions included in a chapter have been specially created and compiled to enable students solve complex problems which require strenuous effort with promptness.

These MCQs are framed considering the importance given to every topic as per the NEET-UG & JEE (Main) exam to form a strong foundation. They are a healthy mix of theoretical, numerical, reactions and graphical based questions.

The level of difficulty of these questions is at par with that of various competitive examinations held across India. Questions from various examinations such as NEET (UG), JEE (Main), MHT CET, KCET, WB JEE, AP EAMCET, TS EAMCET, AP EAPCET, GUJ CET are exclusively covered.

Features in each chapter:

- Coverage of '**Theoretical Concepts**' that form a vital part of any competitive examination.
- '**Multiple Choice Questions**' are segregated topic-wise to enable easy assimilation of questions based on the specific concept.
- '**Formulae**' covers all the key formulae in the chapter, making it useful for students to glance at while solving problems and revising at the last minute.
- '**Topic Test**' has been provided at the end of each chapter to assess the level of preparation of the student on a competitive level.

All the features of this book pave the path of a student to excel in examination. The features are designed keeping the following elements in mind: Time management, easy memorization or revision and non-conventional yet simple methods for MCQ solving.

We hope the book benefits the learner as we have envisioned.

A book affects eternity; one can never tell where its influence stops.

Publisher

Edition: Eighth

The journey to create a complete book is strewn with triumphs, failures and near misses. If you think we've nearly missed something or want to applaud us for our triumphs, we'd love to hear from you.

Please write to us on: mail@targetpublications.org

Disclaimer

This reference book is based on the NEET (UG) and JEE (Main) syllabus prescribed by National Testing Agency (NTA). We the publishers are making this reference book which constitutes as fair use of textual contents which are transformed by adding and elaborating, with a view to simplify the same to enable the students to understand, memorize and reproduce the same in examinations.

This work is purely inspired upon the course work as prescribed by the National Council of Educational Research and Training (NCERT). Every care has been taken in the publication of this reference book by the Authors while creating the contents. The Authors and the Publishers shall not be responsible for any loss or damages caused to any person on account of errors or omissions which might have crept in or disagreement of any third party on the point of view expressed in the reference book.

© reserved with the Publisher for all the contents created by our Authors.

No copyright is claimed in the textual contents which are presented as part of fair dealing with a view to provide best supplementary study material for the benefit of students.

KEY FEATURES

Quick Review

'Quick Review' Quick review includes tables/ flow chart to summarize the key points in chapter.

Quick Review

Formulae

'Formulae' cover all of the key formulae in the chapter which is useful for students while solving problems and revising at last minute at a glance.

Formulae

Examples

'Examples' are provided to elucidate a concept using theory or MCQ or numerical question and help students hone their problem-solving skills.

Examples

Smart Keys

Smart Keys comprise a set of remarkable study techniques contrived to benefit students.

Smart Keys

Caution

'Caution' apprises students about mistakes which are made while solving an MCQs.

Caution

Smart Tips

'Smart Tips' comprise important theoretical or formula based short tricks considering their usage in solving MCQ.

Smart Tips

Think out of the box

'Think out of the box' reveals quick witted approach to crack the specific question.

Think out of the box

Smart Code

'Smart Code' showcases simple and smart mnemonic created for selected concepts.

Smart Code

Remember This

'Remember This' includes key points, important reactivity orders, exceptions, point of difference, misconceptions, etc.

Remember This

To be continued...

For your knowledge

'For your knowledge' includes additional information relevant to concept.

For your knowledge

Connection

'Connection' enables students to interlink concepts covered in different chapters.

Connection

Gyan Guru

'Gyan Guru' illustrates real life applications or examples related to the concept discussed.

Gyan Guru

Clock symbol

'Clock Symbol' instructs students that given MCQ can be solved apace by applying either Smart tips or Think out of the box.

Clock

QR Code

'QR code' provides:

- Access to a video/PDF in order to boost understanding of a concept or activity.
- Solutions to Topic Test of each chapter.
- Solutions to question papers of
 - JEE (Main) 2024 31st January (Shift - 1)
 - NEET (UG) 2024

QR Code

Frequently Asked Questions

➤ Why Absolute Series?

Gradually, every year the nature of competitive entrance exams is inching towards conceptual understanding of topics. Moreover, it is time to bid adieu to the stereotypical approach of solving a problem using a single conventional method.

To be able to successfully crack the NEET/JEE (Main) examinations, it is imperative to develop skills such as data interpretation, appropriate time management, knowing various methods to solve a problem, etc. With Absolute Series, we are sure, you'd develop all the aforementioned skills and take a more holistic approach towards problem solving. The way you'd tackle advanced level MCQs with the help of Hints, Solved examples, Smart tips, Smart codes and Think out of the box would give you the necessary practice that would be a game changer in your preparation for the competitive entrance examinations.

➤ What is the intention behind the launch of Absolute Series?

The sole objective behind the introduction of Absolute Series is to cater to needs of students across a varied background and effectively assist them to successfully crack the NEET/JEE (Main) examinations. With a healthy mix of MCQs, we intend to develop a student's MCQ solving skills within a stipulated time period.

➤ What do I gain out of Absolute Series?

After using Absolute Series, students would be able to:

- assimilate the given data and apply relevant concepts with utmost ease.
- tackle MCQs of different pattern such as match the columns, diagram based questions, multiple concepts and assertion-reason efficiently.
- garner the much needed confidence to appear for competitive exams.
- easy and time saving methods to tackle tricky questions will help ensure that time consuming questions do not occupy more time than you can allot per question.

➤ How to derive the best advantage of the book?

To get the maximum benefit of the book, we recommend :

- Go through the detailed theory and Examples solved alongwith at the beginning of a chapter for concept clarity. Commit Smart tips into memory and pay attention to Caution, Remember This.
- Read through the Quick review section to summarize the key points in chapter.
- Know all the Formulae compiled at the end of theory by heart.
- Using subtopic wise segregation as a leverage, complete MCQs in each subtopic at your own pace. Questions from exams such as JEE (Main), NEET-UG are tagged and placed along the flow of subtopic. Mark these questions specially to gauge the trends of questions in various exams.
- Be extra receptive to Think out of the box, Alternate Method and application of Smart tips. Assimilate them into your thinking.

Best of luck to all the aspirants!

CONTENTS

No.	Topic Name	Page No.	Answers and Solutions
1	Some Basic Concepts of Chemistry	1	500
2	Structure of Atom	34	515
3	Classification of Elements and Periodicity in Properties	76	529
4	Chemical Bonding and Molecular Structure	104	536
5	Thermodynamics	159	554
6	Equilibrium	205	571
7	Redox Reactions	267	594
8	Some p-Block Elements	294	602
9	Organic Chemistry - Some Basic Principles and Techniques	317	606
10	Hydrocarbons	389	621
•	JEE (Main) 2024 31 st January (Shift – I) Question Paper & Answer Key	663	
•	NEET (UG) 2024 Question Paper & Answer Key	665	

Solving previous year papers is the best way to work on your strength, weaknesses, and time management.

Scan the adjacent QR Code to know more about our **"37 Years NEET PSP (Previous Solved Papers)"** of NEET UG Entrance examination.



Get an overall idea of the type of questions that are asked in the NEET UG Examination.

Scan the adjacent QR Code to know more about our **"Previous 12 Years NEET solved papers with Solutions"** book for the NEET UG Entrance examination.



Practice test Papers are the only way to assess your preparedness for the Exams.

Scan the Adjacent QR code to know more about our **"NEET (UG) Test Series with Answer Keys & Solutions"** of Physics, Chemistry and Biology books for the NEET UG Entrance examination.



Do you want to improve your score of NEET-UG Examination?

Scan the Adjacent QR code to know more about our **"NEET UG 10 Full Syllabus Mock Tests"** book.



2

Structure of Atom

- Wave nature of light
- Quantum theory of radiation
- Bohr's model for hydrogen atom
- Concept of shells and subshells
- Dual nature of matter: de Broglie's relationship
- Heisenberg's uncertainty principle
- Quantum mechanical model of an atom: Concept of atomic orbitals
- Quantum numbers
- Shapes of orbitals
- Rules for filling electrons in orbitals
- Electronic configurations of atoms
- Stability of half filled and completely filled orbitals

WAVE NATURE OF LIGHT

➤ Wave Theory:

- In 1864, **Maxwell** found that an alternating current of high frequency radiated energy in the form of waves which travelled in space with the same speed as that of light.
- Maxwell called these waves **electromagnetic waves** or **electromagnetic radiations**, because they were associated with both, electric and magnetic fields.
- This gave birth to a new theory known as the '**wave theory of light.**'



GG - Gyan Guru

Water waves !!

Electromagnetic waves resemble waves flowing across a body of water. However, water waves oscillate only up and down, while electromagnetic waves have two components: an oscillating electric field and an oscillating magnetic field.



➤ Salient features of wave theory of light:

- Light is transmitted in the form of electromagnetic waves.
- These electromagnetic waves are associated with electric and magnetic waves directed at right angles to each other and also perpendicular to the direction of propagation of the wave.
- All electromagnetic waves travel with the same velocity, which is equal to the velocity of light.
- Electromagnetic waves do not require any medium for propagation or transmission.

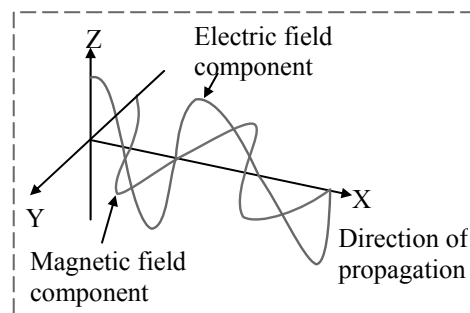

➤ Wave motion:

- A **wave** is a periodic disturbance in space and **wave motion** represents the propagation of this periodic disturbance which carries energy.
- A wave originates from the point of disturbance and propagates in the form of up and down movements.
- As the wave moves, amplitude of the wave goes on increasing till it attains a maximum value. This point of maximum amplitude is called **crest**.
- As the wave moves further, the amplitude decreases and attains the value of zero at the line of propagation. On further movement, the amplitude decreases on the negative side and attains minimum value.



- v. The point corresponding to this minimum value of the amplitude (on the negative side) is called a **trough**.
- vi. Beyond this point, the amplitude again increases resulting in a crest.
- vii. Thus, a continuous sequence of alternate crests and troughs is obtained during wave motion.

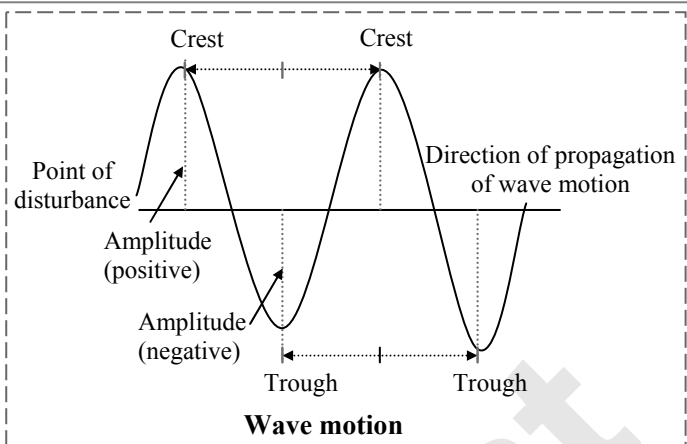

➤ **Characteristics of wave motion:**

i. **Wavelength (λ):**

*The distance between two consecutive crests or troughs is called **wavelength**.*

It is represented by Greek letter λ (lambda). It is generally measured in Angstrom unit (\AA) or nanometer (nm).

$$\begin{aligned} 1 \text{ \AA} &= 10^{-8} \text{ cm} = 10^{-10} \text{ m} \\ 1 \text{ nm} &= 10^{-9} \text{ m} = 10 \text{ \AA} \end{aligned}$$

ii. **Frequency (ν):**

*The number of waves passing through a reference point in one second is called **frequency**.*

It is represented by Greek letter ' ν ' (nu). It is expressed in the unit cycles per second (cps) or Hertz (Hz).

1 Hz = 1 cycle per second

The unit kilo Hertz (kHz) and mega Hertz (mHz) are common in use.

$$\begin{aligned} 1 \text{ kHz} &= 10^3 \text{ Hz} = 10^3 \text{ cps} \\ 1 \text{ mHz} &= 10^6 \text{ Hz} = 10^6 \text{ cps} \end{aligned}$$

iii. **Velocity (c):**

*The distance travelled by a wave in one second is called the **velocity** of the wave.*

It is denoted by letter c .

Velocity of wave (light) = frequency \times wavelength

$$\therefore c = \nu\lambda$$

The velocity of all types of electromagnetic radiation in space or in vacuum is the same and it is equal to the velocity of light. i.e., $3 \times 10^{10} \text{ cm s}^{-1}$ or $3 \times 10^8 \text{ m s}^{-1}$

Thus, all types of electromagnetic radiations travel with the same velocity. However, they may differ from one another in their wavelengths and hence in frequencies.



Smart tip - 1

For any two electromagnetic radiations, $\nu_1\lambda_1 = \nu_2\lambda_2$

iv. **Wave number ($\bar{\nu}$):**

*The number of waves which can be accommodated in a unit length (usually 1 cm) is called the **wave number**.*

It is represented by ($\bar{\nu}$) and read as 'nu bar'. It is generally expressed in the unit cm^{-1} .

Wave number of a wave is equal to the reciprocal of its wavelength in cm.

$$\bar{\nu} = \frac{1}{\lambda}$$

Relationship between ν and $\bar{\nu}$: $\nu = \frac{c}{\lambda} = c(\bar{\nu})$



v. **Amplitude (A):**

The height of a crest or the depth of a trough from the line of propagation of the wave is called **amplitude**.

It is represented by the letter 'A'. The amplitude of the wave determines the intensity (brightness) of the radiation.

EXAMPLE - 2.1

What is the approximate wavelength (in nanometres) of the electromagnetic radiation of frequency 1.0×10^{15} per second?

Solution:

$$c = v \lambda$$

$$\therefore \lambda = \frac{3.0 \times 10^8 \text{ ms}^{-1}}{1.0 \times 10^{15} \text{ s}^{-1}}$$

$$= 3.0 \times 10^{-7} \text{ m} = 3.0 \times 10^{-7} \times 10^9 \text{ nm} = \mathbf{300 \text{ nm}}$$

➤ **Electromagnetic spectrum:**

- The arrangement of different types of electromagnetic radiations in the order of increasing wavelength is called **electromagnetic spectrum**.
- Wavelength of visible radiations lie between **400 nm** (violet) to **760 nm** (red).
- It forms a small portion of the electromagnetic spectrum.
- Infrared and ultraviolet radiations are on either sides of the visible spectrum.

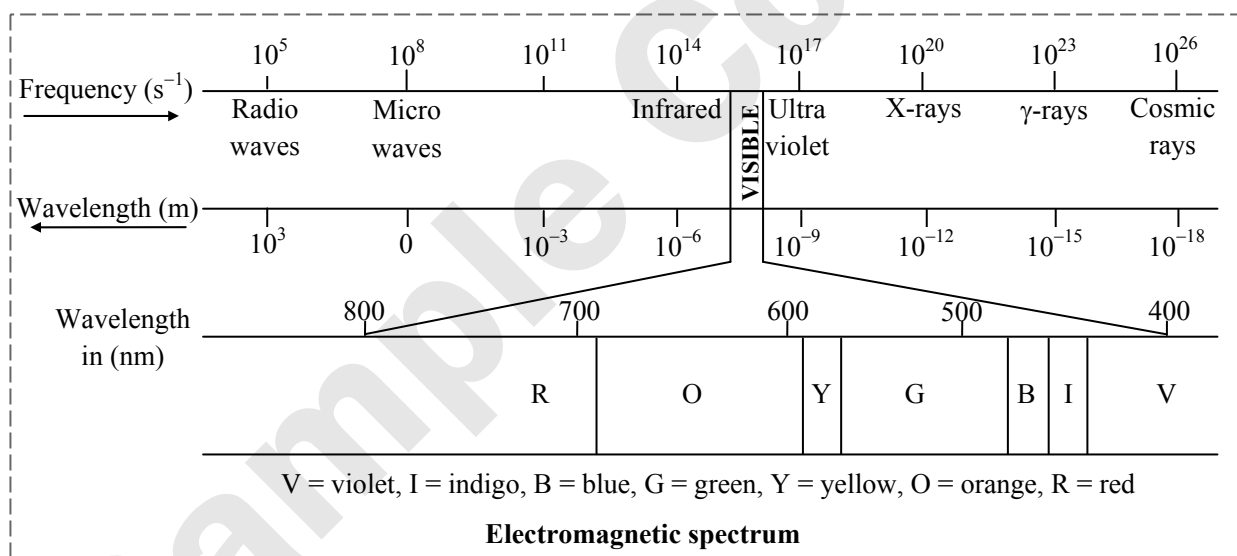

Smart code - 1

Order of **increasing frequency** of electromagnetic radiation:

Radio waves < Microwaves < Infrared < Visible < Ultraviolet < X-rays < Gamma rays < Cosmic rays

Ronald McDonald Invented Very Unusual but eXcellent Gamma and Cosmic rays.

QUANTUM THEORY OF RADIATION

➤ **Newton's corpuscular theory:**

- Light is a form of energy. In order to explain the nature of light, **Newton** proposed a theory known as **Corpuscular Theory**.
- As per this theory, light is composed of tiny particles known as **corpuscles**.
- This theory successfully explained the phenomenon of reflection and refraction but failed to explain the phenomenon of interference and diffraction.

➤ **Drawbacks of wave theory:**

- i. Wave nature of light could explain phenomenon such as diffraction (bending of wave around an obstacle) and interference (a phenomenon in which two waves superpose to form a resultant wave of greater, lower, or same amplitude).
- ii. However, wave nature could not explain the following observations;
 - a. the nature of emission of radiation from hot bodies (black - body radiation)
 - b. ejection of electrons from metal surface when radiation strikes it (photoelectric effect)
 - c. variation of heat capacity of solids as a function of temperature
 - d. line spectra of atoms with special reference to hydrogen

➤ **Black body radiation:**

- i. A black body is an ideal body which absorbs any wavelength of light incident on it and hence, when heated, emits all wavelengths.
- ii. The amount of energy radiated per unit volume, by a black body depends upon temperature. The energy radiated at a particular temperature is not of a single frequency.
- iii. The plot of amount of energy radiated (intensity) vs wavelength at different temperatures is shown in the graph.

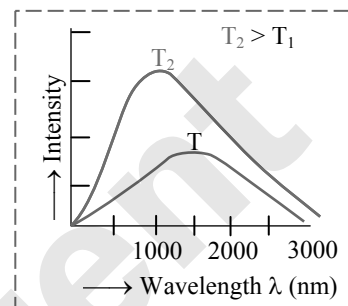
➤ **Planck's quantum theory of radiation:**

To explain these radiations, **Max Planck** put forward a theory known as **Planck's quantum theory**.

- i. The radiant energy which is emitted or absorbed by the black body is not continuous but discontinuous in the form of small discrete packets of energy; each such packet of energy is called as '**quanta**'. In case of light, the quantum of energy is called as '**photon**'.
- ii. The energy of each quantum is directly proportional to the frequency (ν) and inversely proportional to the wavelength (λ) of the radiation,

$$E \propto \nu \quad \text{or} \quad E = h\nu \quad \text{or} \quad E = \frac{hc}{\lambda} \quad \text{or} \quad E \propto \frac{1}{\lambda}$$

Where, h = Planck's constant = 6.626×10^{-27} erg. sec. or 6.626×10^{-34} Joule sec (J s)

- iii. The total amount of energy emitted or absorbed by a body will be some whole number of **quanta** or **photons**. Hence, $E = nh\nu$, where, n is an integer.

**REMEMBER THIS**

The longer the wavelength of a particular radiation, the smaller is its frequency and also, the lower is the energy of the radiation.

EXAMPLE - 2.2

The energy of a 500 nm photon is _____ J.

Solution:

Energy of a photon is given by:

$$\begin{aligned} E = h\nu &= \frac{hc}{\lambda} \\ &= \frac{6.626 \times 10^{-34} \times 3 \times 10^8}{500 \times 10^{-9}} \quad [500 \text{ nm} = 500 \times 10^{-9} \text{ m}] \\ &= 3.98 \times 10^{-19} \text{ J} \end{aligned}$$

➤ **Photoelectric effect:**

*When radiations with certain minimum frequency (ν_0) strike the surface of a metal, electrons are ejected from the surface. This phenomenon is called **photoelectric effect** and the electrons emitted are called **photo-electrons**.*

- i. The electrons are ejected only if the radiation striking the surface of the metal has at least a minimum frequency (ν_0) called **threshold frequency**. The minimum potential at which the plate's photoelectric current becomes zero is called **stopping potential**.



- ii. The velocity or kinetic energy of the electrons ejected depends upon the frequency of the incident radiation and is independent of its intensity.
- iii. The number of photoelectrons ejected is proportional to the intensity of incident radiation.
- iv. **Einstein's photoelectric effect equation:**

According to Einstein, if the striking photon has energy equal to $h\nu$ and the minimum energy required to eject the electron is $h\nu_0$ (also called **work function**, W_0), then the difference in energy ($h\nu - h\nu_0$) is transferred as the kinetic energy of the photoelectron.

Maximum kinetic energy of the ejected electrons = Absorbed energy – Threshold energy

$$\frac{1}{2}mv_{\max}^2 = h\nu - h\nu_0 = hc \left[\frac{1}{\lambda} - \frac{1}{\lambda_0} \right]$$

Where, ν_0 and λ_0 are threshold frequency and threshold wavelength respectively.

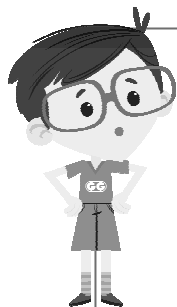

GG - Gyan Guru

Photoelectric effect in remote control !!

The photoelectric effect has uses in our daily lives through technology such as TV remote control devices and motion sensors. When we press the power button on a TV remote, the remote emits a beam of infrared light that impinges on the "electric eye" in the television set. The resulting emission of electrons signals the television to turn on or off.



EXAMPLE - 2.3

A certain metal has a work function of 7.6×10^{-19} J. Can a remote control producing light of wavelength 900 nm eject electrons from this metal surface?

Solution:

The minimum energy required to eject electrons is $W_0 = 7.6 \times 10^{-19}$ J

Energy of a photon that can be obtained from the remote control is calculated as follows:

$$\begin{aligned} E = h\nu &= \frac{hc}{\lambda} \\ &= \frac{6.626 \times 10^{-34} \times 3 \times 10^8}{900 \times 10^{-9}} = 2.2 \times 10^{-19} \text{ J} \end{aligned}$$

The energy of the radiation is lower than the work function (W_0). Therefore, the remote control **will not eject photoelectrons** from this metal surface.

- v. **Dual behaviour of electromagnetic spectrum:**
 - a. Particle nature of light could explain the black body radiation and photoelectric effect satisfactorily but on the other hand, it was not consistent with the known wave behaviour of light which could account for the phenomena of interference and diffraction.
 - b. Hence, the idea that light possesses both particle and wave-like properties, i.e., light has dual behaviour was accepted.
 - c. Depending on the experiment, we find that light behaves either as a wave or as a stream of particles. Whenever radiation interacts with matter, it displays particle like properties in contrast to the wavelike properties (interference and diffraction), which it exhibits when it propagates.
- **Evidence of quantized electronic energy levels: Atomic spectra**
 - i. Ordinary white light consists of waves with all the wavelengths in the visible range.
 - ii. When a ray of white light is passed through a prism the light spreads out into a series of coloured bands called spectrum. The spectrum of white light that we can see ranges from violet at 7.50×10^{14} Hz to red at 4×10^{14} Hz. Such a spectrum is called **continuous spectrum**.
 - iii. When electromagnetic radiation interacts with matter, atoms and molecules may absorb energy and jump to an unstable higher energy state.
 - iv. For returning to their normal (more stable), lower energy state, the atoms and molecules emit radiations in various regions of the electromagnetic spectrum.



- **Emission and absorption spectra:**

- A spectrum of electromagnetic radiation transmitted through a substance, showing dark lines or bands due to absorption at specific wavelengths is called **absorption spectra**.
- The spectrum of radiation emitted by a substance that has absorbed energy is called an **emission spectrum**.
- The spectrum of visible light is continuous as all wavelengths (red to violet) of the visible light are represented in the spectra.
- On the other hand, the emission spectra of atoms in the gas phase, do not show a continuous spread of wavelengths. They emit light only at specific wavelengths. Such spectra are called **line spectra** or **atomic spectra**.
- Each element has unique line emission spectra. The characteristic lines in atomic spectra can be used in chemical analysis to identify unknown elements. Of all the elements, hydrogen atom has the simplest line spectrum.

- **Line spectrum of hydrogen:**

- When an electric discharge is passed through hydrogen gas in a discharge tube, H_2 molecules dissociate and the energetically excited hydrogen atoms produced emit radiation of discrete frequencies.
- This series of lines is known as line or atomic spectrum of hydrogen.

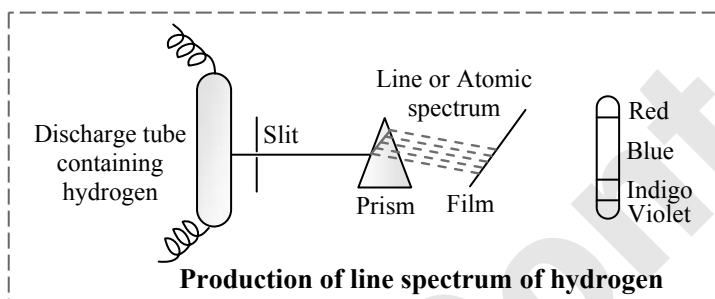

- Each line of the spectrum corresponds to a light of definite wavelength.
- The entire spectrum consists of five series of lines, each series being named after its discoverer.

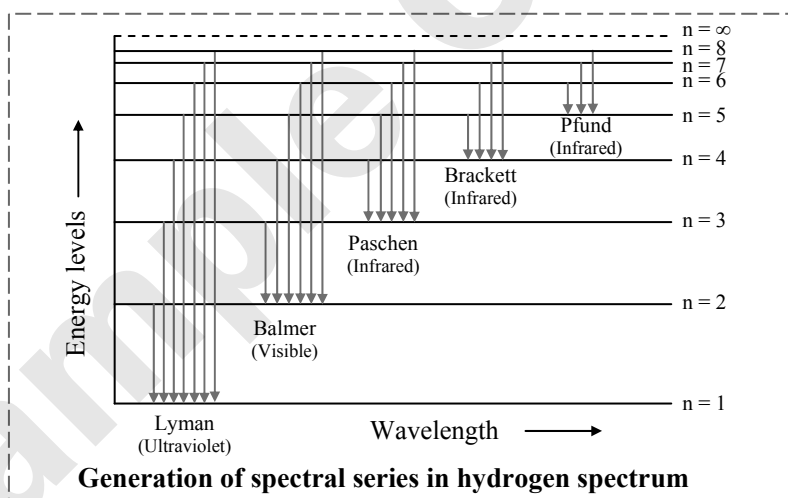

- The Swedish spectroscopist, Johannes Rydberg, noted that all series of lines in the hydrogen spectrum could be described by the following expression:

$$\bar{\nu} = \frac{1}{\lambda} = R \left(\frac{1}{n_1^2} - \frac{1}{n_2^2} \right) = 109,677 \left(\frac{1}{n_1^2} - \frac{1}{n_2^2} \right) \text{ cm}^{-1}$$

where $n_1 = 1, 2, \dots$

$n_2 = n_1 + 1, n_1 + 2, \dots$

The value $109,677 \text{ cm}^{-1}$ is called the **Rydberg constant** for hydrogen.

**Smart tip - 2**

When an atom absorbs radiation of frequency, ν or wavelength, λ and emits two photons of frequency ν_1 and

ν_2 or wavelength λ_1 and λ_2 , then $\nu = \nu_1 + \nu_2$ or $\frac{1}{\lambda} = \frac{1}{\lambda_1} + \frac{1}{\lambda_2}$



BOHR'S MODEL FOR HYDROGEN ATOM

➤ Bohr's model of an atom:

Niels Bohr modified Rutherford's model of an atom and proposed a model for the hydrogen atom. The model explained the atomic spectrum of hydrogen atom and the stability of the atom.

• Postulates:

- Electrons revolve around the nucleus in concentric circular paths called **orbits** situated at a definite distance from the nucleus.
- There are stationary orbits for electrons. As long as the electrons revolve in these stationary orbits, they do not radiate energy. The energies of electrons remain constant in stationary orbits.
- Different **stationary levels** or **stationary orbits** or **shells** are represented by capital letters **K, L, M, N** with corresponding shell numbers 1, 2, 3, 4, etc.

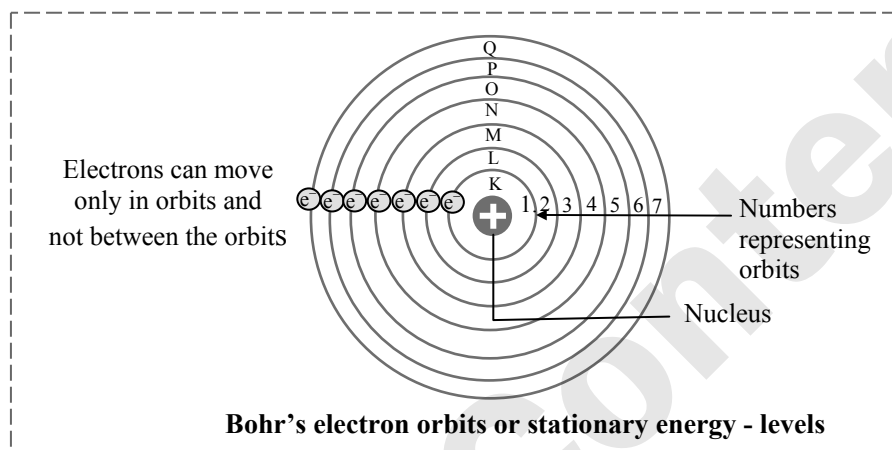

- An electron can revolve only in those stationary orbits, without radiating energy, for which the angular momentum of an electron is an integral multiple of $h/2\pi$.

$$\therefore mvr = n \frac{h}{2\pi}$$

where, m = mass of the electron ; v = linear velocity of the electron

r = radius of orbit ; h = Planck's constant

n = integral number called principal quantum number

($n = 1$ for K shell, 2 for L shell, 3 for M shell, 4 for N shell etc.)

- Energy goes on increasing as stationary level goes farther from the nucleus.
- A definite amount of energy or quantum of energy is absorbed when an electron jumps from a lower energy level to the higher energy level. Similarly, a definite amount of energy is given out when an electron jumps from a higher energy level to a lower energy level. The energy absorbed or emitted is the difference between energies of these two stationary levels.
- The frequency of radiation absorbed or emitted when transition occurs between two stationary states that differ in energy by ΔE , is given by:

$$\nu = \frac{\Delta E}{h} = \frac{E_2 - E_1}{h}$$

where E_1 and E_2 are the energies of the lower and higher allowed energy states respectively. This expression is known as **Bohr's frequency rule**.

➤ Merits of Bohr's model:

Bohr's model of an atom successfully explained the atomic spectra of H and H-like atoms and also provided a reasonable explanation to the stability of an atom.

i. It explains the stability of an atom:

According to Bohr's theory, an electron neither gains nor loses energy while moving in a particular shell. It implies that if an atom is not disturbed, its constituent electron will go on moving in the specified orbit forever and the atom will remain stable.

ii. Energy of electron in a particular orbit can be determined:

From the postulates of Bohr's theory, an expression for the calculation of the energy of an electron in a particular orbit can be derived.



$$E_n = - \left[\frac{2\pi^2 m Z^2 e^4}{n^2 h^2} \right]$$

where, E_n = Energy of the electron in the n^{th} orbit, Z = atomic number of the atom

For H atom, $Z = 1$

m = mass of electron = 9.1×10^{-31} kg

e = magnitude of charge on the electron = 1.602×10^{-19} C

h = Planck's constant = 6.626×10^{-34} J s

Substituting these values,

$$E_n = - \frac{2.18 \times 10^{-18}}{n^2} \text{ J atom}^{-1}$$

$$= - \frac{(13.6)}{n^2} \text{ eV atom}^{-1} (\because 1 \text{ eV} = 1.602 \times 10^{-19} \text{ J})$$

$$= - \frac{1311.8}{n^2} \text{ kJ mol}^{-1} \text{ or } \approx - \frac{1312}{n^2} \text{ kJ mol}^{-1} \text{ or } - \frac{313.6}{n^2} \text{ kcal mol}^{-1}$$

**REMEMBER THIS**

$$E_n \propto - \frac{1}{n^2} \quad (\text{when } Z \text{ is constant})$$

EXAMPLE - 2.4

Which of the following corresponds to the energy of the possible excited state of hydrogen?

[TS EAMCET 2017]

- (A) -13.6 eV (B) 13.6 eV (C) -3.4 eV (D) 3.4 eV

Solution:

For hydrogen atom,

$$E_n = \frac{-13.6}{n^2} \text{ eV}$$

For excited state, $n > 1$.

$$\text{When } n = 2, E_2 = \frac{-13.6}{(2)^2} = -3.4 \text{ eV}$$

$$\text{When } n = 3, E_3 = \frac{-13.6}{(3)^2} = -1.5 \text{ eV}$$

\therefore Among the given options, the energy of a possible excited state of hydrogen is -3.4 eV.

Ans: (C)

Note: Negative sign for the energy of an electron in any orbit in a hydrogen atom indicates that the energy of the electron in the atom is lower than the energy of a free electron at rest. A free electron at rest is an electron that is infinitely far away from the nucleus and is assigned the energy value of zero.

As the electron gets close to the nucleus, value of 'n' decreases and E_n becomes large in absolute value and more negative. The negative sign corresponds to attractive forces between electron and nucleus.

**Smart tip - 3**

For hydrogen-like species, i.e. species containing only one electron, the energy of electron in the n^{th} energy levels can be calculated using following formulae:

$$E_n = - (2.18 \times 10^{-18}) \times \frac{Z^2}{n^2} \text{ J atom}^{-1} \quad \text{OR} \quad E_n = - (13.6) \frac{Z^2}{n^2} \text{ eV atom}^{-1}$$

EXAMPLE - 2.5

Energy of an electron of Li^{2+} in third Bohr orbit is _____ J/atom.

Solution:

Using *Smart tip - 3*,

$$\begin{aligned} E_n &= - \frac{2.18 \times 10^{-18}}{n^2} \times Z^2 = \frac{-2.18 \times 10^{-18}}{3^2} \times 3^2 \\ &= - 2.18 \times 10^{-18} \text{ J/atom} \end{aligned}$$



iii. **Radius of Bohr's orbit can be determined:**

As the electron of an atom revolves in one of the stationary orbital, the coulombic force of attraction between the nucleus and the electron, i.e. $\frac{Ze^2}{r^2}$ must be equal to the centrifugal force of the electron, $\frac{mv^2}{r}$.

$$\therefore \frac{Ze^2}{r^2} = \frac{mv^2}{r} \quad \dots(1)$$

$$\therefore r = \frac{Ze^2}{mv^2}$$

According to Bohr's postulates, angular momentum of an electron mvr is an integral multiple of $\frac{nh}{2\pi}$.

$$\therefore mvr = \frac{nh}{2\pi}$$

$$\therefore v = \frac{nh}{2\pi mr}$$

Substituting 'v' in equation (1), we get

$$r = \frac{n^2 h^2}{4\pi^2 m Z e^2}$$

Substituting values of h, m, Z = 1 for hydrogen and e, the electronic charge, radius may be calculated as,

$$r = 0.529 \times n^2 \text{ \AA}$$

$$\therefore r_n = a_0 \times n^2 \text{ \AA}$$

where $a_0 = 0.529 \text{ \AA}$.

Thus, the radius of the first stationary state, called the **Bohr orbit** is 0.529 \AA .

For $n = 1$, $r = 0.529 \text{ \AA}$

$n = 2$, $r = 2.116 \text{ \AA}$

$n = 3$, $r = 4.761 \text{ \AA}$

$n = 4$, $r = 8.464 \text{ \AA}$

$n = 5$, $r = 13.225 \text{ \AA}$

and so on. This also suggests that electrons take up only discrete energy levels.



REMEMBER THIS

$$r_n \propto n^2 \quad (\text{when } Z \text{ is constant})$$



Smart tip - 4

For hydrogen-like species, i.e. species containing only one electron, the radius of the n^{th} orbit is given as:

$$r_n = 0.529 \times \frac{n^2}{Z} \text{ \AA}$$

EXAMPLE - 2.6

The radius of the 2nd orbit of B^{4+} ion is _____.

[TS EAMCET (Engg.) 2019]

- (A) 4.23 \AA (B) 0.2340 \AA (C) 0.4232 \AA (D) 0.3241 \AA

Solution:

$n = 2$ and $Z = 5$

Using *Smart tip - 4*,

$$r_n = \frac{0.529 \times (2)^2}{5} = 0.4232 \text{ \AA}$$

Ans: (C)

iv. **Velocity of the electron can be determined:**

It is also possible to calculate the velocities of electrons moving in these orbits. Although the precise equation is not given here, qualitatively the magnitude of velocity of electron increases with increase of positive charge on the nucleus and decreases with increase of principal quantum number (n).

$$v_n = 2.18 \times 10^6 \left(\frac{Z}{n} \right) \text{ m s}^{-1}$$

**For your knowledge**

The total energy of an electron (E_{Total}) in any orbit is given as:

$$E_{\text{Total}} = E_{\text{K.E.}} + E_{\text{P.E.}}$$

$$\text{Kinetic energy (K.E.)} = \frac{1}{2} \frac{Zke^2}{r}$$

$$\text{Potential energy (P.E.)} = -\frac{Zke^2}{r}$$

$$E_{\text{Total}} = \frac{1}{2} \frac{Zke^2}{r} - \frac{Zke^2}{r} = -\frac{1}{2} \frac{Zke^2}{r}$$

Therefore, Total energy = $\frac{1}{2}$ (potential energy) = – kinetic energy

➤ **Bohr's theory and atomic spectrum of hydrogen:**

i. According to Bohr's theory, the energy of an electron in the n^{th} orbit is given by,

$$E_n = -\frac{2\pi^2mZ^2e^4}{n^2h^2}$$

where, n takes up only integral values like 1, 2, 3, 4 ...etc. and is called **principal quantum number (n)**.

ii. For hydrogen atom, the energy of electron varies with $\frac{1}{n^2}$.

$$\therefore E \propto -\frac{1}{n^2}$$

$$\therefore E_1 = \frac{K}{(1)^2} = K$$

$$\text{Now, } E_2 = \frac{K}{(2)^2} = \frac{K}{4} = \frac{E_1}{4} \text{ (as, } E_1 = K)$$

$$\begin{aligned} \text{Hence, for } n = 1, & E_1 = E_1 \\ n = 2, & E_2 = E_1/4 \\ n = 3, & E_3 = E_1/9 \\ n = 4, & E_4 = E_1/16 \end{aligned}$$

Hence, energy of electron does not change continuously. It changes discontinuously.

iii. Consider the electron in the higher shell n_2 . The energy of the electron in the shell n_2 is given by,

$$E_{n_2} = -\frac{2\pi^2mZ^2e^4}{n_2^2h^2}$$

The electron emits a quantum of energy given by $\Delta E = h\nu$ and the electron jumps to shell n_1 .

The energy of electron in shell n_1 is given by,

$$E_{n_1} = -\frac{2\pi^2mZ^2e^4}{n_1^2h^2}$$

\therefore The change in energy of electron (or the energy gap between the two orbits) is given as

$$\Delta E = E_{n_2} - E_{n_1} = h\nu$$

$$\therefore h\nu = -\frac{2\pi^2mZ^2e^4}{n_2^2h^2} + \frac{2\pi^2mZ^2e^4}{n_1^2h^2}$$

$$\therefore h\nu = \frac{2\pi^2mZ^2e^4}{h^2} \left[\frac{1}{n_1^2} - \frac{1}{n_2^2} \right]$$

$$\therefore \nu = \frac{2\pi^2mZ^2e^4}{h^3} \left[\frac{1}{n_1^2} - \frac{1}{n_2^2} \right] \quad \dots(1)$$

iv. The wave number corresponding to frequency, $\bar{\nu} = \frac{\nu}{c}$

$$\therefore \bar{\nu} = \frac{2\pi^2mZ^2e^4}{h^3 \times c} \left[\frac{1}{n_1^2} - \frac{1}{n_2^2} \right] \quad \dots(2) \text{ (Ritz equation)}$$



- v. Now, compare equations (1) and (2),
Eq. (1) is similar to the equation of Ritz combination principle, for the wave number of the lines in the atomic spectrum of hydrogen, given by

$$\bar{\nu} = R \left[\frac{1}{n_1^2} - \frac{1}{n_2^2} \right] \quad \therefore \quad R = \frac{2\pi^2 m Z^2 e^4}{h^3 c}$$

Where, R is **Rydberg constant**, and its value was reported to be $109677.58 \text{ cm}^{-1}$. From known values of m, Z, e, h and c, the new value of R was calculated to be $109677.61 \text{ cm}^{-1}$.

- vi. The radiation (energy) emitted if the electron moves from higher orbit (n_2) to lower orbit (n_1) is given as:

$$\Delta E = -2.18 \times 10^{-18} \left[\frac{1}{n_1^2} - \frac{1}{n_2^2} \right] \text{ J} = -13.6 \left[\frac{1}{n_1^2} - \frac{1}{n_2^2} \right] \text{ eV}$$

- vii. The Bohr's model of an atom gives a very logical explanation of the existence of a large number of lines in the atomic spectrum of hydrogen. When an electron de-excites from a higher energy level to a lower energy level, it emits energy. The energy thus emitted is quantized and corresponds to a definite frequency or wavelength. This forms the basis of the existence of a large number of well defined lines in the atomic spectrum of hydrogen.

In the line spectrum, each spectral line is a due to a particular transition associated with a particular frequency or wavelength.

Limiting line of the series	First line of the series
$n_2 = \infty$	$n_2 = (n_1 + 1)$
Minimum wavelength (or maximum wave number)	Maximum wavelength (or minimum wave number)
$\frac{1}{\lambda_{\min}} = \bar{\nu}_{\max} = R \left(\frac{Z^2}{n_1^2} \right)$	$\frac{1}{\lambda_{\max}} = \bar{\nu}_{\min} = R Z^2 \left[\frac{1}{n_1^2} - \frac{1}{(n_1 + 1)^2} \right]$



Smart tip - 5

When electron jumps from higher energy orbit (n_2) to lower energy orbit (n_1) in Bohr's atom, the possible number of spectral lines (N) is given by the following formula:

$$N = \frac{(n_2 - n_1)(n_2 - n_1 + 1)}{2}$$

➤ Ionization energy:

*The energy required to remove most loosely bonded electron from the normal ground state of the atom is called the **ionization energy**.*

$$\text{Ionization energy } (E_{\text{ionisation}}) = E_{\infty} - E_{\text{Ground state}}$$

For H-atom, $E_{\infty} = 0$ and $E_{\text{Ground state}} = E_1 = -2.18 \times 10^{-18} \text{ J}$

$$\therefore \text{ Ionization energy of H-atom} = 0 - (-2.18 \times 10^{-18}) = 2.18 \times 10^{-18} \text{ J} = 13.6 \text{ eV}$$



Smart tip - 6

For hydrogen-like species, i.e. species containing only one electron, the ionization energy is given as:

$$E_{\text{ionisation}} = 2.18 \times 10^{-18} \times (Z)^2 \text{ J} = 13.6 \times (Z)^2 \text{ eV}$$

➤ Drawbacks of Bohr's model:

- Bohr's model fails to explain the atomic spectra for elements containing more than one electron.
- When the hydrogen spectrum is observed by using spectrometer of high resolving power, it is observed that individual lines are not single but consist of several fine lines lying close together. Such a hyperfine spectrum could not be explained by Bohr's theory.
- The model fails to explain the splitting of atomic spectral lines in the presence of external magnetic field (**Zeeman effect**) and external electric field (**Stark effect**).
- It could not explain the ability of atoms to form molecules by chemical bonds.

**CONCEPT OF SHELLS AND SUBSHELLS**➤ **Shells:**

- According to Bohr's atomic model, in an atom, electrons revolve around the nucleus in various stationary energy levels which are called **orbits**. These orbits are called **principal energy levels** or **shells**.
- Each shell has a different energy level. The first shell, nearest to the nucleus, known as the 'K' shell, has maximum energy, followed by the second shell L, and so on.
- The principal quantum number, $n = 1, 2, 3, 4, 5, 6$ for K, L, M, N, O, P shells respectively.
- Each shell contains $2n^2$ electrons (where, n is the principal quantum number). Thus, K-shell accommodates maximum 2 electrons, L-shell accommodates 8 electrons, etc.

➤ **Distribution of electrons in various shells:**

The number of electrons in any shell is given by the expression $2n^2$, where $n = 1, 2, 3, \dots$

Hence,

Shell	n	Number of electrons
K	1	2
L	2	8
M	3	18
N	4	32
O	5	50
P	6	72

➤ **Number and designation of subshells:**

The number of subshells in a shell is equal to **n**.

Principal Shell	n	Number of subshells	Designation of subshells
K	1	1	1s
L	2	2	2s, 2p
M	3	3	3s, 3p, 3d
N	4	4	4s, 4p, 4d, 4f

➤ **Accommodation of electrons in a given subshell:**

The maximum number of electrons in a given subshell is given by $2(2l + 1)$.

Thus, s-subshell ($l = 0$) has 2 electrons

p-subshell ($l = 1$) has 6 electrons

d-subshell ($l = 2$) has 10 electrons

f-subshell ($l = 3$) has 14 electrons

DUAL NATURE OF MATTER: DE BROGLIE'S RELATIONSHIP➤ **De Broglie's relationship:**

- In 1924, the French physicist, **Louis de Broglie** suggested that if light has both particle and wave like nature, the similar duality must be true for matter. Thus an electron, behaves both as a material particle and as a wave.
- This presented a new wave mechanical theory of matter. According to this theory, small particles like electrons when in motion possess wave properties.
- According to de-Broglie, the wavelength associated with a particle of mass m , moving with a velocity v is given by the relation,

$$\lambda = \frac{h}{mv}, \text{ where, } h = \text{Planck's constant.}$$

- This can be derived as follows,

According to Planck's equation, $E = hv = \frac{hc}{\lambda}$

Energy of photon (on the basis of Einstein's mass energy relationship), $E = mc^2$

Equating both $\frac{hc}{\lambda} = mc^2$ or $\lambda = \frac{h}{mc}$, which is same as de-Broglie relation. ($\because mc = p$), $p = \text{momentum}$.



- v. This was experimentally verified by **Davisson and Germer** by observing diffraction effects with an electron beam. Let the electron be accelerated with a potential of V , then the Kinetic energy is,
- $$\frac{1}{2}mv^2 = eV; m^2v^2 = 2eVm$$
- $$mv = \sqrt{2eVm} = p; \lambda = \frac{h}{\sqrt{2eVm}}$$
- vi. If Bohr's theory is associated with de-Broglie's equation then wavelength of an electron can be determined in Bohr's orbit and related with circumference and multiplied by a whole number.
- $$2\pi r = n\lambda \text{ or } \lambda = \frac{2\pi r}{n}$$
- From de-Broglie's equation, $\lambda = \frac{h}{mv}$.
- Thus, $\frac{h}{mv} = \frac{2\pi r}{n}$ or $mvr = \frac{nh}{2\pi}$
- vii. The de-Broglie equation is applicable to all material objects but has significance only in case of **microscopic particles**. Since, we come across macroscopic objects in our everyday life, de-Broglie relationship has no significance in everyday life.

EXAMPLE - 2.7

Calculate the de Broglie wavelength associated with a particle of mass 10^{-6} kg moving with a velocity of 10 m s^{-1} .

Solution:

Mass of the particle (m) = 10^{-6} kg and velocity of the particle (v) = 10 m s^{-1}

$$\lambda = \frac{h}{mv} = \frac{6.626 \times 10^{-34}}{10^{-6} \times 10}$$

$$= 6.626 \times 10^{-29} \text{ m}$$

**For your knowledge**

De Broglie's research on wave nature of electron created confusion among scientist community. The University of Paris where De Broglie studied wanted further scrutinization of his research. So, they sent his work to Albert Einstein for review. Einstein found De Broglie's work "very interesting". This endorsement was good enough to accept De Broglie's research. Later, he was awarded Nobel Prize for his work.

However, the questions arose to locate electrons as it has both, particle as well as wave nature. The question has one answer if electron is treated as a particle and quite different answer if it treated as a wave. Later, Werner Heisenberg addressed this issue. The wavelength of electron is quite small that one would need gamma rays to locate it. However, gamma rays possess enormous amount of energy and they simply would knock out electron. Hence, it would be difficult to determine position of electron and its momentum simultaneously.

Students can scan the adjacent Q.R. code in *Quill - The Padhai App* visualize **wave model of an electron**.



GG - Gyan Guru

Electron microscopes!

In a microscope, the size of the smallest features we can see is limited by the wavelength used. The discovery that electrons behave as waves led to the development of the electron microscope which uses a beam of accelerated electrons as a source of illumination. The wavelength of an electron can be up to 100,000 times shorter than that of visible light photons and so, electron microscopes can reveal the structure of smaller objects.

**HEISENBERG'S UNCERTAINTY PRINCIPLE****➤ Heisenberg's uncertainty principle:**

Statement: *It is impossible to specify at any given moment both the position and momentum (velocity) of an electron with absolute accuracy.*

i. Mathematically it is represented as,

$$\Delta x \cdot \Delta p \geq \frac{h}{4\pi}$$

Where,

Δx = uncertainty in the position of the particle

Δp = uncertainty in the momentum of the particle

Now, since $\Delta p = m\Delta v$

So equation becomes, $\Delta x \cdot m\Delta v \geq \frac{h}{4\pi}$ or $\Delta x \cdot \Delta v \geq \frac{h}{4\pi m}$

ii. In terms of uncertainty in energy ΔE and uncertainty in time Δt , this principle is written as,

$$\Delta E \cdot \Delta t \geq \frac{h}{4\pi}$$

• Significance of uncertainty principle:

- Heisenberg's uncertainty principle rules out existence of definite paths or trajectories of electrons and other similar particles.
- The effect of Heisenberg uncertainty principle is significant only for motion of microscopic objects and is negligible for that of macroscopic objects.
- In the case of a microscopic object like an electron on the other hand, $\Delta v \cdot \Delta x$ obtained is much larger and such uncertainties are of real consequence.
- The precise statements of the position and momentum of electrons have to be replaced by the statements of probability, that the electron has at a given position and momentum.

Students can scan the adjacent Q.R. code in *Quill - The Padhai App* visualize demonstration of **Heisenberg's Uncertainty Principle**.

**EXAMPLE - 2.8**

Uncertainty in position of a particle weighing 0.25 g is 10^{-5} m. Calculate uncertainty in velocity.

[$h = 6.6 \times 10^{-34}$ J s]

Solution:

According to Heisenberg's uncertainty principle, $\Delta x \times m \times \Delta v = \frac{h}{4\pi}$

$$\begin{aligned} \Delta v &= \frac{h}{\Delta x \times m \times 4\pi} \\ &= \frac{6.6 \times 10^{-34}}{10^{-5} \times 0.25 \times 10^{-3} \times 3.14 \times 4} = 2.1 \times 10^{-26} \text{ m/s} \end{aligned}$$

➤ Reasons for the failure of Bohr model:

- The wave character of the electron is not considered in Bohr model. In Bohr model, an electron is regarded as a charged particle moving in circular orbits.
- Further, an orbit is a clearly defined path and this path can completely be defined only if both the position and the velocity of the electron are known exactly at the same time, which is not possible according to Heisenberg's uncertainty principle.
- Bohr model of the hydrogen atom, therefore, not only ignores dual behaviour of matter but also contradicts Heisenberg uncertainty principle.
- Thus, an insight into the structure of the atom was needed which could account for wave-particle duality of matter and be consistent with Heisenberg uncertainty principle, which led to the advent of quantum mechanics.



QUANTUM MECHANICAL MODEL OF AN ATOM: CONCEPT OF ATOMIC ORBITALS

➤ Schrodinger wave equation:

- Schrodinger wave equation was given by **Erwin Schrodinger** in 1926 and is based on dual nature of electron.
- In this, electron is described as a three dimensional wave in the electric field of a positively charged nucleus.
- The probability of finding an electron at any point around the nucleus can be determined with the help of Schrodinger wave equation which is,

$$\frac{\partial^2\Psi}{\partial x^2} + \frac{\partial^2\Psi}{\partial y^2} + \frac{\partial^2\Psi}{\partial z^2} + \frac{8\pi^2m}{h^2} (E - V) \Psi = 0$$

Where x , y and $z = 3$ space co-ordinates

m = mass of electron

h = Planck's constant

E = Total energy

V = Potential energy of electron

Ψ = Amplitude of wave or Wave function

∂ = for an infinitesimal change.

- The Schrodinger wave equation can also be written as,

$$\nabla^2\Psi + \frac{8\pi^2m}{h^2}(E - V)\Psi = 0$$

Where, ∇ = Laplacian operator.

➤ Physical significance of Ψ and Ψ^2 :

- The **wave function Ψ** represents the amplitude of the electron wave. The amplitude Ψ is thus a function of space co-ordinates and time i.e., $\Psi = \Psi(x, y, z, \dots, \text{time})$
- For a single particle, the square of the wave function (Ψ^2) at any point is proportional to the probability of finding the particle at that point.
- If Ψ^2 is maximum then probability of finding electron, e^- is maximum around nucleus and the place where probability of finding e^- is maximum is called **electron density, electron cloud** or **an atomic orbital**. It is different from the Bohr's orbit.
- The solution of this equation provides a set of number called **quantum numbers** which describe specific or definite energy state of the electron in an atom and information about the shapes and orientations of the most probable distribution of electrons around the nucleus.

➤ Radial probability distribution curves:

- In order to visualize, the electron cloud within a spherical shell is placed at radii ' r ' and ' $r + dr$ ' from the nucleus.
- Thus radial probability function describes the total probability of finding the electron in a spherical shell of thickness ' dr ' located at the distance r from the nucleus.
- Radial probability function (R.P.F.) is given as follows,

$$\begin{aligned} \text{R.P.F} &= (\text{Volume of spherical shell}) \times \text{Probability density} \\ &= (4\pi r^2 dr) \times \Psi^2 \end{aligned}$$

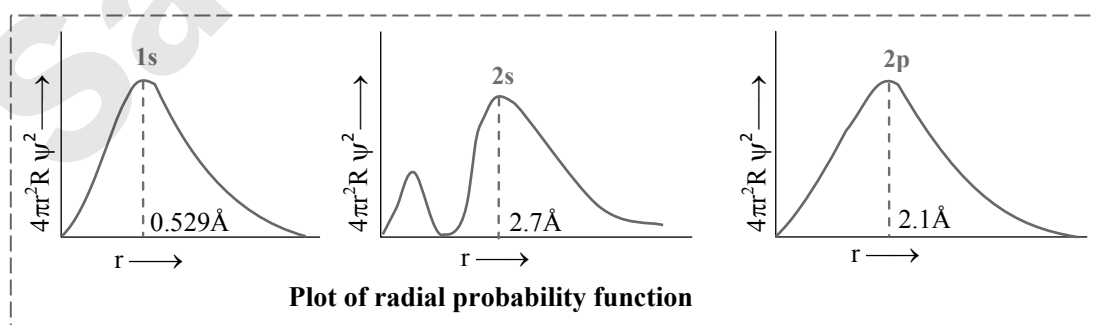

Smart tip - 7

In the plot of radial probability function against ' r ', the number peaks = $n - l$.

➤ **Difference between orbit and orbital:**

No.	Orbit	Orbital
i.	It is a well defined circular path around the nucleus in which electrons revolve according to Bohr's model of an atom.	It is a three dimensional space around the nucleus in which the probability of finding an electron is maximum and this is in accordance with the quantum mechanical model of an atom.
ii.	An orbit can accommodate $2n^2$ electrons, where n represents the number of the orbit.	An orbital can accommodate maximum 2 electrons only.
iii.	The revolution of an electron in an orbit is against the Heisenberg's uncertainty principle.	The concept of an orbital is in accordance with the Heisenberg's uncertainty principle.
iv.	Orbits are circular.	The probability distribution of a charge cloud in different orbitals is different. This gives them different shapes.
v.	Orbits are non-directional.	Except s-orbital, all other orbitals are directional in nature.

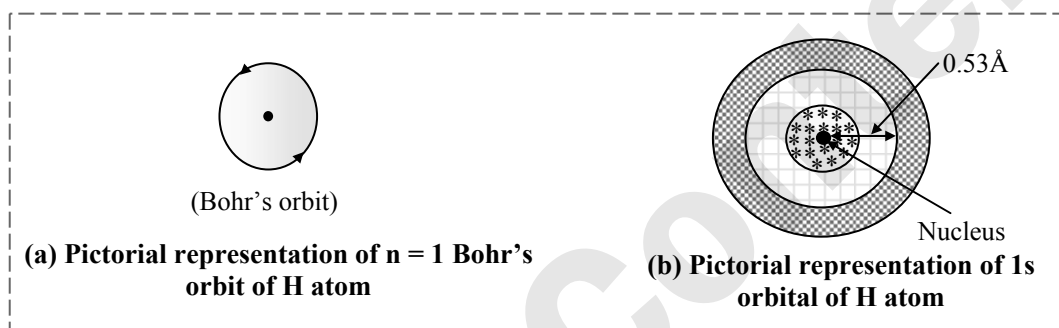
**QUANTUM NUMBERS**➤ **Quantum number:**

Each orbital in an atom is specified by a set of three quantum numbers (n, l, m) and each electron is designated by a set of four quantum numbers (n, l, m and s).

• **Principal quantum number (n):**

- It was proposed by **Bohr** and denoted by ' n '.
- It determines the average distance between electron and nucleus, means it denotes the size of orbit.
- It determines the energy of the electron in an orbit where electron is present.
- It gives an idea about position of an electron around the nucleus.
- The maximum number of electrons in a shell is represented by this quantum number as $2n^2$. No energy shell in atoms of known elements possesses more than 32 electrons.
- It gives the information of shell K, L, M, N, O, P, Q or 1, 2, 3, 4, 5, 6, 7
- Angular momentum** can also be calculated using principal quantum number.

• **Azimuthal quantum number (l):**

- Azimuthal quantum number is also known as **angular quantum number**. It was proposed by **Sommerfeld** and denoted by ' l '.
- It determines the number of subshells or sub-levels to which the electron belongs.
- It tells about the shape of subshells.
- It also expresses the energies of subshells $s < p < d < f$ (increasing energy).
- The value of $l = 0$ to $(n - 1)$ always, where ' n ' is the number of principal shell.

Values of l	Name of subshell	Shape of subshell
0	s	Spherical
1	p	Dumb-bell
2	d	Double dumb-bell
3	f	Complex

- It represents the orbital angular momentum, which is equal to $\frac{h}{2\pi}\sqrt{l(l+1)}$.



- vii. The maximum number of electrons in a subshell = $2(2l + 1)$
 $l = 0$, s subshell \rightarrow 2 electrons
 $l = 1$, p subshell \rightarrow 6 electrons
 $l = 2$, d subshell \rightarrow 10 electrons
 $l = 3$, f subshell \rightarrow 14 electrons

• **Magnetic quantum number (m or m_l):**

- It was proposed by **Zeeman** and denoted by 'm' or ' m_l '.
- It gives the number of permitted orientation of sub-shells.
- The value of 'm' varies from $-l$ to $+l$ through zero.
- It tells about the splitting of spectral lines in the magnetic field i.e., this quantum number proves the **Zeeman effect**.
- For a given value of 'n', the total value of 'm' is equal to n^2 .
- For a given value of 'l', the total value of 'm' is equal to $(2l + 1)$.
- Degenerate orbitals: *Orbitals having the same energy are known as degenerate orbitals.*
E.g. For p-subshell, degenerate orbitals are p_x , p_y , and p_z .
- The number of degenerate orbitals of 's' subshell = 0.

Values of l and corresponding values of m:

Values of l	Subshells	Values of m ($-l$ to $+l$)	Total number of values of m	No. of orbitals	Maximum no. of electrons
0	s	0	One value of m so one orbital i.e. s-orbital	1	2
1	p	-1, 0, +1	Three values of m, so three orbitals p_x , p_y , p_z	3	6
2	d	-2, -1, 0, +1, +2	Five values of m so five orbitals	5	10
3	f	-3, -2, -1, 0, +1, +2, +3	Seven values of m so seven orbitals	7	14

• **Spin quantum number (s or m_s):**

- It was proposed by **Uhlenbeck** and **Goldschmidt** and denoted by 's' or ' m_s '.
- Spin quantum number arises due to spin of electron about its own axis.
- The spin of electron can be clockwise represented by $\frac{1}{2}$ or \uparrow or it can be anticlockwise represented by $-\frac{1}{2}$ or \downarrow .
- If two electrons possess the same sign of spin quantum number then these are known to have parallel spin $\uparrow\uparrow$ or $\downarrow\downarrow$.
- If two electrons have opposite spin, they are represented as $\uparrow\downarrow$.
- Spin quantum number is the only quantum number that has non-integral value.

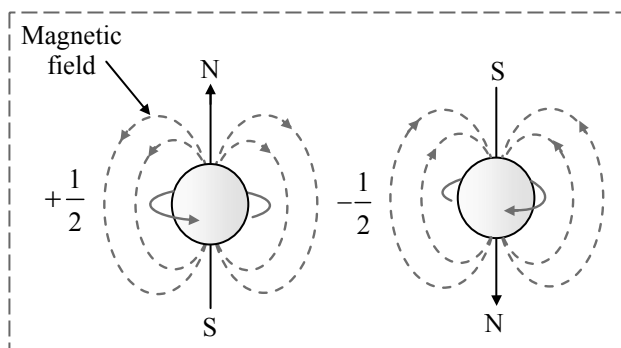

➤ **Values of quantum number l and m for $n = 1$ to 4 principal shell:**

Principal Shell	Values of n	Values of l (0 to $n-1$)	Values of m ($-l$ to $+l$)	Values of s	Total No. of electrons
K	1	$l = 0$ (s)	$m = 0$	$\pm 1/2$	2
L	2	$l = 0$ (s)	$m = 0$	$\pm 1/2$	8
			$m = -1$	$\pm 1/2$	
		$l = 1$ (p)	$m = 0$	$\pm 1/2$	
			$m = +1$	$\pm 1/2$	



M	3	$l = 0$ (s)	$m = 0$	$\pm 1/2$	18
		$l = 1$ (p)	$m = -1$	$\pm 1/2$	
			$m = 0$	$\pm 1/2$	
	$l = 2$ (d)	$m = +1$	$\pm 1/2$		
		$m = -2$	$\pm 1/2$		
		$m = -1$	$\pm 1/2$		
		$m = 0$	$\pm 1/2$		
		$m = +1$	$\pm 1/2$		
		$m = +2$	$\pm 1/2$		
N	4	$l = 0$ (s)	$m = 0$ (s)	$\pm 1/2$	32
		$l = 1$ (p)	$m = -1$	$\pm 1/2$	
			$m = 0$	$\pm 1/2$	
			$m = +1$	$\pm 1/2$	
		$l = 2$ (d)	$m = -2$	$\pm 1/2$	
			$m = -1$	$\pm 1/2$	
	$m = 0$		$\pm 1/2$		
	$m = +1$		$\pm 1/2$		
	$m = +2$		$\pm 1/2$		
	$m = +3$		$\pm 1/2$		
	$l = 3$ (f)	$m = -3$	$\pm 1/2$		
		$m = -2$	$\pm 1/2$		
		$m = -1$	$\pm 1/2$		
		$m = 0$	$\pm 1/2$		
		$m = +1$	$\pm 1/2$		
$m = +2$		$\pm 1/2$			
$m = +3$		$\pm 1/2$			

SHAPES OF ORBITALS

➤ s-Orbital:

- For s-orbitals, $l = 0$. For $l = 0$, $m = 0$. This shows that s-orbital have only one orientation.
- They are **spherically symmetrical about the nucleus**.
- For each value of principal quantum number 'n', there is only one orientation.
- There is only one symmetrical orbital for each value of n whose radius depends upon the value of n.

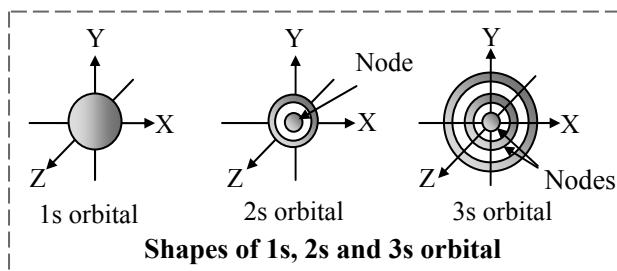

- The size and energy of the 's' orbital increases with increase in principal energy level. It is in the order $4s > 3s > 2s > 1s$.
- In between 1s and 2s, there is a region where probability of finding the electron is zero. It is called as **node**.

➤ p-Orbitals:

- For p-orbital, $l = 1$. For $l = 1$, $m = +1, 0, -1$. p orbitals have three orientations.
- Each orbital consists of two lobes.
- Shape of p-orbital resembles a dumb-bell. The two lobes are separated by a plane having zero electron density. Such a plane is called **nodal plane**.
- These three p-orbitals are designated as p_x , p_y and p_z . They are perpendicular to each other and oriented along X, Y and Z axes respectively, in space.
- They are equivalent in energy in the absence of magnetic field.
- They have directional character that determines the geometry of molecules.
- The size and energy of p-orbital increases with increase in principal energy level. It is in the order, $4p > 3p > 2p$.

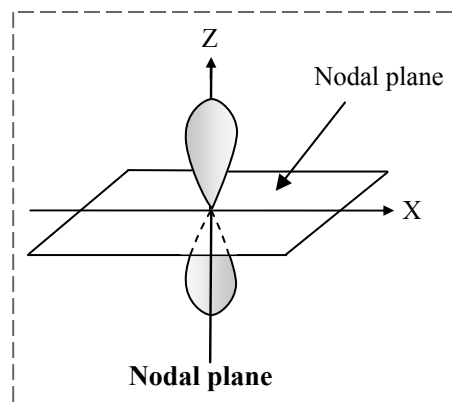

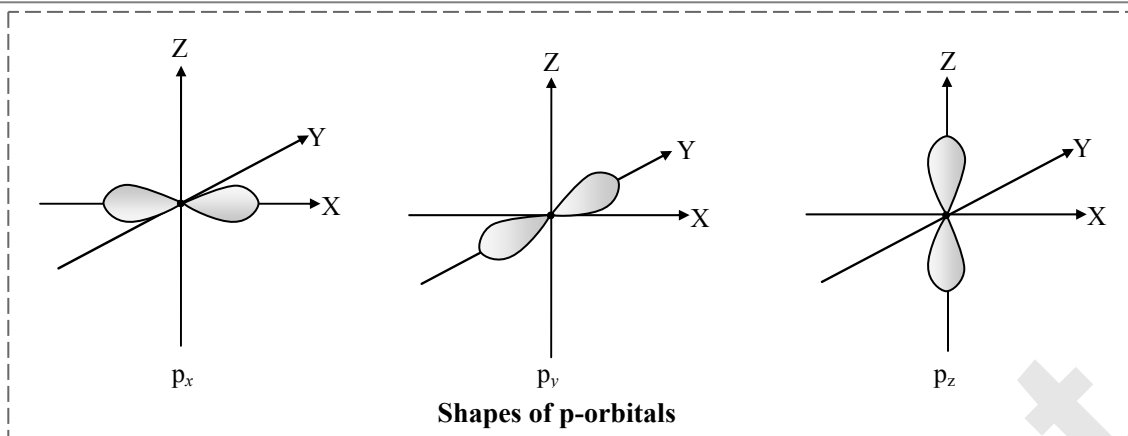

➤ **d-Orbitals:**

- i. For d orbital, $l = 2$. For $l = 2$, $m = +2, +1, 0, -1, -2$.
- ii. d orbitals have five orientations. They are designated as d_{xy} , d_{yz} , d_{zx} , $d_{x^2-y^2}$ and d_{z^2} .
- iii. They are all equivalent in energy in the absence of magnetic field.
- iv. The first three have double dumb-bell shape in XY, YZ and XZ plane, respectively.
- v. The $d_{x^2-y^2}$ is also dumb-bell shaped and lies along the X and Y axes.
- vi. d_{z^2} is dumb-bell shaped with a dough-nut shaped ring of high electron density around the nucleus in XY plane.

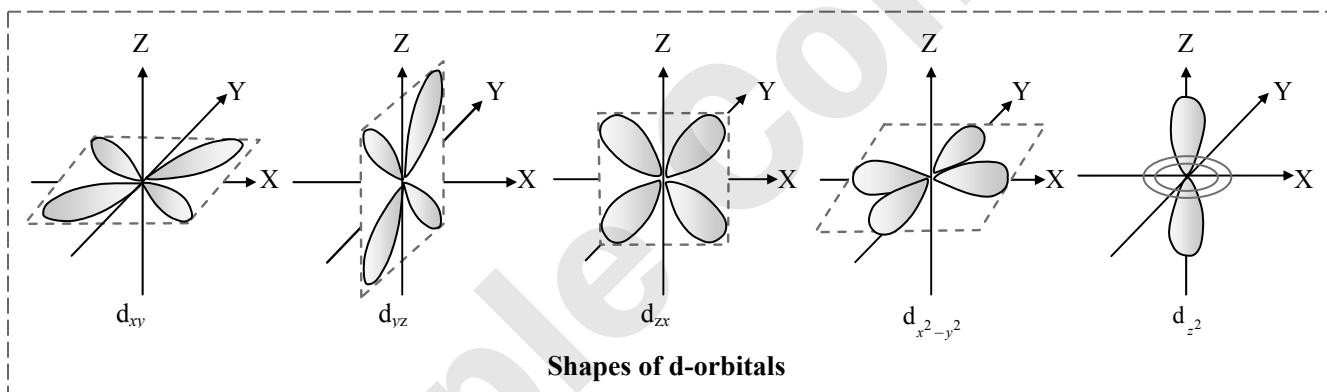

➤ **f-Orbitals:**

- i. For the 'f' orbital, $l = 3$ then the values of 'm' are $-3, -2, -1, 0, +1, +2, +3$. Thus, 'f' orbital has seven orientations.
- ii. The 'f' orbital is complicated in shape.

➤ **Spherical (radial) nodes:**

*A spherical surface within an orbital on which the probability of finding the electron is zero is called **spherical or radial node**.*

The number of spherical or radial nodes in an orbital = $(n - l - 1)$.

- E.g.** 1s orbital ($n = 1, l = 0$) has no spherical node.
 2s orbital ($n = 2, l = 0$) has one spherical node.
 3p orbital ($n = 3, l = 1$) has one spherical node.

➤ **Nodal plane:**

*A plane passing through the nucleus on which the probability of finding an electron is zero is called a **nodal plane**.*

The number of nodal planes (also known as angular nodes) in an orbital is equal to l .

- E.g.** s-orbital ($l = 0$) has no nodal plane.
 p-orbital ($l = 1$) has one nodal plane.
 d-orbital ($l = 2$) has two nodal planes.



- **Energies of orbitals:**
- The energy of an electron in a hydrogen atom is determined solely by the principal quantum number (n). Thus, the energy of the orbitals increases as follows:
 $1s < 2s = 2p < 3s = 3p = 3d < 4s = 4p = 4d = 4f$
 - Although the shapes of 2s and 2p orbitals are different, an electron has the same energy when it is in the 2s orbital as when it is present in 2p orbital. The orbitals having same energies are called **degenerate**.
 - The 1s orbital in a hydrogen atom corresponds to the most stable condition and is called the **ground state** and an electron residing in this orbital is most strongly held by the nucleus. An electron in the 2s, 2p or higher orbitals in a hydrogen atom is in **excited state**.
 - The energy of an electron in a multi-electron atom, depends on both its principal quantum number (shell) and azimuthal quantum number (sub-shell). For a given principal quantum number; s, p, d, f ... all have different energies.
 - The main reason for having different energies of the sub-shells is the mutual repulsion among the electrons in a multi-electron atom.
- vi. **Effective nuclear charge (Z_{eff}):**
- The stability of an electron in multi-electron atom is because total attractive interactions (between electron and nucleus) are more than the repulsive interactions (between electrons).
 - Attractive interactions of an electron increases with increase of positive charge on the nucleus.
 - Inner shell electrons partially shield the outermost electrons from the positive charge of the nucleus. The net positive charge experienced by the outermost electrons is known as **effective nuclear charge**.
- Both the attractive and repulsive interactions depend upon the shell and shape of the orbital in which the electron is present.
 - For a given shell, Z_{eff} experienced by the electron decreases with increase of azimuthal quantum number.
 - The energy of electrons in s orbital will be lower (more negative) than that of p orbital electron which will have less energy than that of d orbital electron and so on. Since the extent of shielding from the nucleus is different for electrons in different orbitals, it leads to the splitting of energy levels within the same shell (or same principal quantum number).
 - The lower the value of $(n + l)$ for an orbital, the lower is its energy. If two orbitals have the same value of $(n + l)$, the orbital with lower value of 'n' will have the lower energy. This is known as **(n + l) rule**.
 - Energies of the orbitals in the same sub-shell decrease with increase in the atomic number (Z_{eff}).
 $E_{2s}(\text{H}) > E_{2s}(\text{Li}) > E_{2s}(\text{Na}) > E_{2s}(\text{K})$.

**Connections**

In chapter 3 (Classification of Elements and Periodicity in Properties), you will study how effective nuclear charge varies across a period and down a group in the modern periodic table, and how it affects various periodic trends.

RULES FOR FILLING ELECTRONS IN ORBITALS

The atom is built up by filling electrons in various orbitals according to the following rules:

➤ **Aufbau principle:**

This principle states that the electrons are added one by one to the various orbitals in order of their increasing energy starting with the orbital of lowest energy.

The increasing order of energy of various orbitals is,

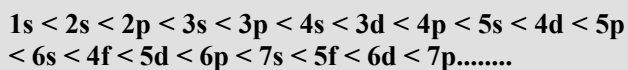

The order may be remembered by using the following method:

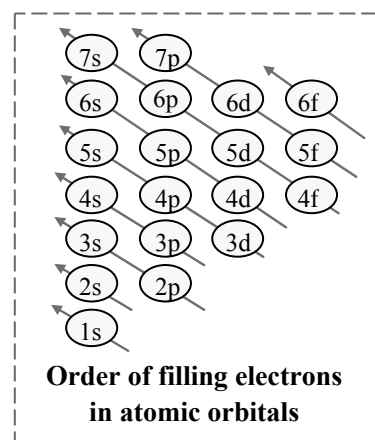



➤ **Pauli's exclusion principle:**

- i. According to this principle,

No two electrons in an atom can have same value of all the four quantum numbers.

- ii. If one electron in an atom has the quantum numbers $n = 1$, $l = 0$, $m = 0$ and $s = +1/2$, no other electron can have the same four quantum numbers. In other words, we cannot place two electrons with the same value of s in an orbital.
- iii. Only two electrons may exist in the same orbital and these electrons must have opposite spins.

Electron number	Quantum number				Set of values of quantum numbers
	n	l	m	s	
1 st electron	1	0	0	$+\frac{1}{2}$	$(1, 0, 0, +\frac{1}{2})$
2 nd electron	1	0	0	$-\frac{1}{2}$	$(1, 0, 0, -\frac{1}{2})$

➤ **Hund's rule of maximum multiplicity:**

- i. This rule deals with the filling of electrons in the orbitals having equal energy (**degenerate orbitals**).
- ii. According to this rule,

Electron pairing in p, d and f orbitals cannot occur until each orbitals of a given subshell contains one electron each or is singly occupied.

- iii. This repulsion can however be minimized if two electrons move as far apart as possible by occupying different degenerate orbitals. All the unpaired electrons in a degenerate set of orbitals will have same spin.
- iv. The important point to be remembered is that all the singly occupied orbitals should have electrons with parallel spins i.e., in the same direction either clockwise or anticlockwise.

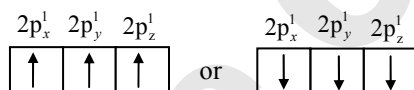

ELECTRONIC CONFIGURATIONS OF ATOMS

➤ **Electronic configuration:**

*The distribution of electrons in various shells, subshells and orbitals of an atom is known as its **electronic configuration**.*

➤ **General representation of electronic configuration of an atom is written as: nl^x**

Where, n = shell number, l = sub shell, x = number of electrons

E.g.

$3p^2$	$3d^1$
3 = shell number ($n = 3$)	3 = shell number ($n = 3$)
p = sub shell ($l = 1$)	d = sub shell ($l = 2$)
2 = number of electrons	1 = number of electrons

➤ **Valence shell electronic configuration:**

*The distribution of electrons in various sub-shells and orbitals of the outermost shell of an atom is called **valence shell electronic configuration**.*

➤ **Pictorial representation of electronic configuration of an atom:**

- i. A circle or a square box is used to represent an orbital and two arrows in the opposite directions represent two electrons with opposite spins.
- ii. Two electrons in an orbital indicate that electrons are paired.

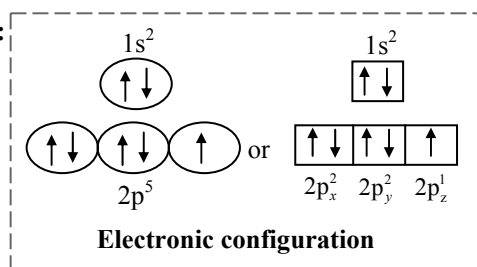



iii. Single electron in an orbital indicates unpaired electron.

➤ **Electronic configurations of the elements with atomic numbers 1 to 30:**

Atomic No.	Element	K (n = 1)	L (n = 2)	M (n = 3)	N (n = 4)	Condensed Outer electronic configuration
1	Hydrogen	1s ¹	-			1s ¹
2	Helium	1s ²	-			1s ²
3	Lithium	1s ²	2s ¹			[He] 2s ¹
4	Beryllium	1s ²	2s ²			[He] 2s ²
5	Boron	1s ²	2s ² 2p ¹			[He] 2s ² 2p ¹
6	Carbon	1s ²	2s ² 2p ²			[He] 2s ² 2p ²
7	Nitrogen	1s ²	2s ² 2p ³			[He] 2s ² 2p ³
8	Oxygen	1s ²	2s ² 2p ⁴			[He] 2s ² 2p ⁴
9	Fluorine	1s ²	2s ² 2p ⁵			[He] 2s ² 2p ⁵
10	Neon	1s ²	2s ² 2p ⁶			[He] 2s ² 2p ⁶
11	Sodium	1s ²	2s ² 2p ⁶	3s ¹		[Ne] 3s ¹
12	Magnesium	1s ²	2s ² 2p ⁶	3s ²		[Ne] 3s ²
13	Aluminium	1s ²	2s ² 2p ⁶	3s ² 3p ¹		[Ne] 3s ² 3p ¹
14	Silicon	1s ²	2s ² 2p ⁶	3s ² 3p ²		[Ne] 3s ² 3p ²
15	Phosphorus	1s ²	2s ² 2p ⁶	3s ² 3p ³		[Ne] 3s ² 3p ³
16	Sulphur	1s ²	2s ² 2p ⁶	3s ² 3p ⁴		[Ne] 3s ² 3p ⁴
17	Chlorine	1s ²	2s ² 2p ⁶	3s ² 3p ⁵		[Ne] 3s ² 3p ⁵
18	Argon	1s ²	2s ² 2p ⁶	3s ² 3p ⁶		[Ne] 3s ² 3p ⁶
19	Potassium	1s ²	2s ² 2p ⁶	3s ² 3p ⁶	4s ¹	[Ar] 4s ¹
20	Calcium	1s ²	2s ² 2p ⁶	3s ² 3p ⁶	4s ²	[Ar] 4s ²
21	Scandium	1s ²	2s ² 2p ⁶	3s ² 3p ⁶ 3d ¹	4s ²	[Ar] 3d ¹ 4s ²
22	Titanium	1s ²	2s ² 2p ⁶	3s ² 3p ⁶ 3d ²	4s ²	[Ar] 3d ² 4s ²
23	Vanadium	1s ²	2s ² 2p ⁶	3s ² 3p ⁶ 3d ³	4s ²	[Ar] 3d ³ 4s ²
24	Chromium	1s ²	2s ² 2p ⁶	3s ² 3p ⁶ 3d ⁵	4s ¹	[Ar] 3d ⁵ 4s ¹
25	Manganese	1s ²	2s ² 2p ⁶	3s ² 3p ⁶ 3d ⁵	4s ²	[Ar] 3d ⁵ 4s ²
26	Iron	1s ²	2s ² 2p ⁶	3s ² 3p ⁶ 3d ⁶	4s ²	[Ar] 3d ⁶ 4s ²
27	Cobalt	1s ²	2s ² 2p ⁶	3s ² 3p ⁶ 3d ⁷	4s ²	[Ar] 3d ⁷ 4s ²
28	Nickel	1s ²	2s ² 2p ⁶	3s ² 3p ⁶ 3d ⁸	4s ²	[Ar] 3d ⁸ 4s ²
29	Copper	1s ²	2s ² 2p ⁶	3s ² 3p ⁶ 3d ¹⁰	4s ¹	[Ar] 3d ¹⁰ 4s ¹
30	Zinc	1s ²	2s ² 2p ⁶	3s ² 3p ⁶ 3d ¹⁰	4s ²	[Ar] 3d ¹⁰ 4s ²

STABILITY OF HALF FILLED AND COMPLETELY FILLED ORBITALS

➤ **Stability of half filled and completely filled sub-shells can be explained on the basis of two factors:**

i. **Symmetrical distribution of electrons:**

- The extra stability of completely filled and half filled sub-shells can be explained in terms of symmetry.
- These subshells possess symmetrical distribution of electrons.
- Electrons in the same sub-shell have equal energy but different spatial distribution. Consequently, their shielding of one-another is relatively small and the electrons are more strongly attracted by the nucleus.

ii. **Exchange energy:**

- The stabilizing effect arises whenever two or more electrons with the same spin are present in the degenerate orbitals of a sub-shell.
- These electrons have a tendency to exchange their positions and the energy released due to this exchange is called **exchange energy**.
- The number of exchanges that can take place is maximum when the sub-shell is either half filled or completely filled.
- As a result the exchange energy is maximum and so is the stability.

E.g.1. Cu has 29 electrons. Its expected electronic configuration is $1s^2 2s^2 2p^6 3s^2 3p^6 4s^2 3d^9$ but in reality the configuration is $1s^2 2s^2 2p^6 3s^2 3p^6 4s^1 3d^{10}$ as this configuration is more stable.



2. Similarly, Cr has 24 electrons. Its expected electronic configuration is $1s^2 2s^2 2p^6 3s^2 3p^6 4s^2 3d^4$ but its observed electronic configuration is $1s^2 2s^2 2p^6 3s^2 3p^6 4s^1 3d^5$.

e. Possible exchange for d^5 configuration is shown in the following figure:

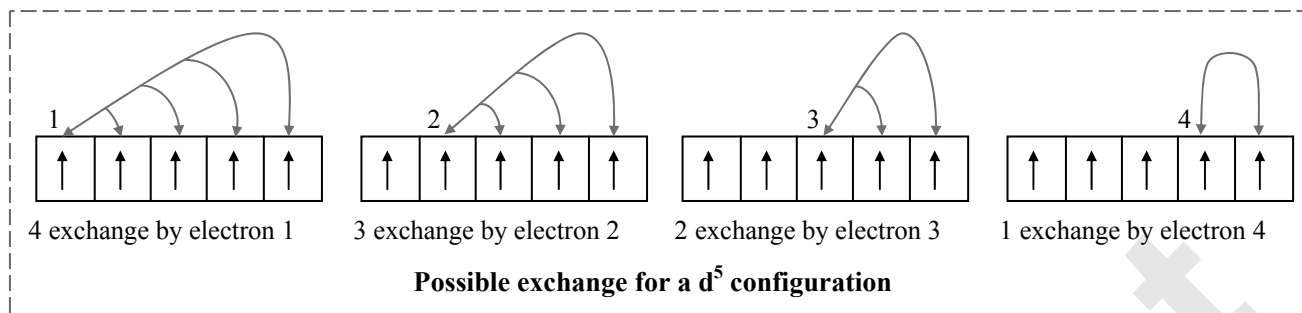

Quick Review

➤ **Series of emission spectral lines for hydrogen:**

Series	n_1	n_2	Spectral region
Lyman	1	2,3,....	Ultraviolet
Balmer	2	3,4,....	Visible
Paschen	3	4,5,....	Infrared
Bracket	4	5,6,....	Infrared
Pfund	5	6,7,....	Infrared

➤ **Evolution of quantum theory:**

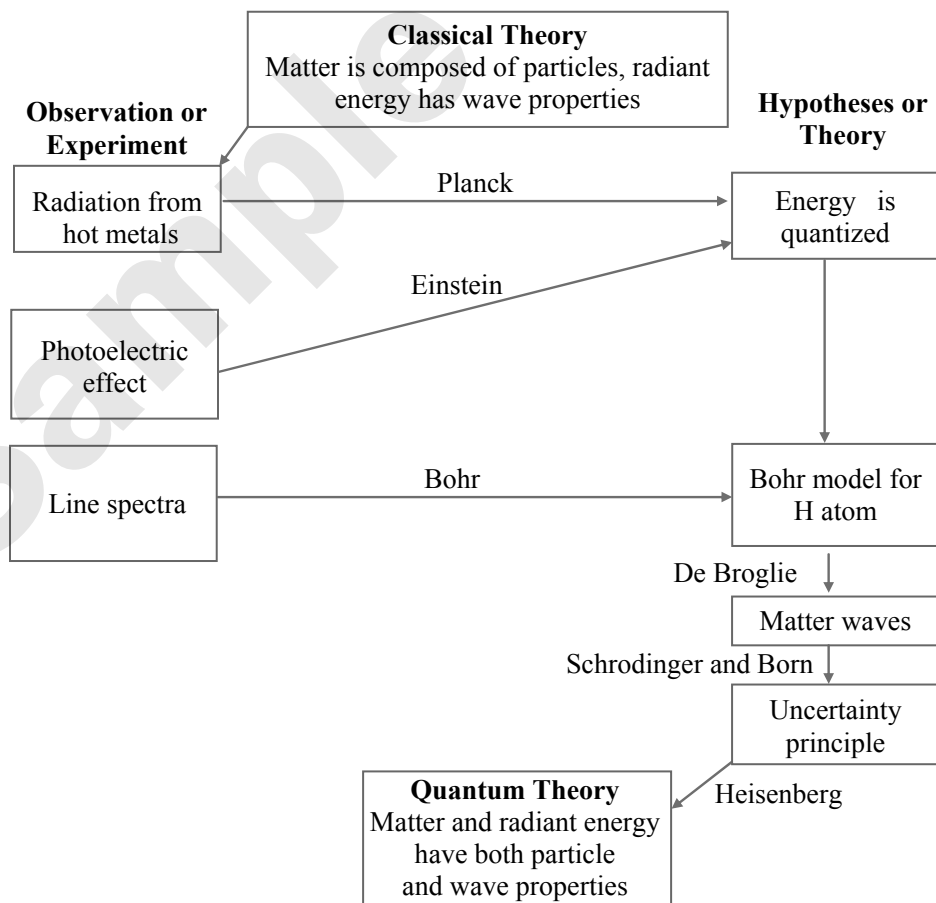

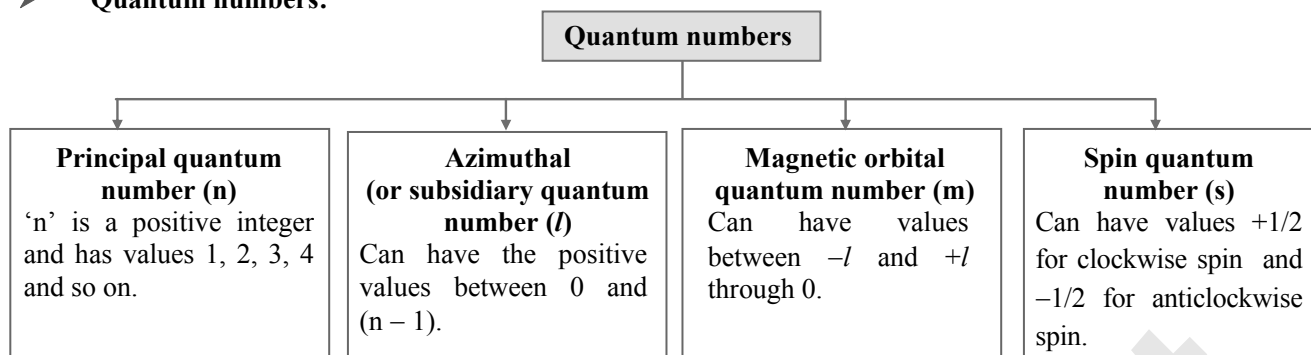
➤ **Quantum numbers:**➤ **Increasing order of energy of various orbitals (multi-electron atom):**

$$1s < 2s < 2p < 3s < 3p < 4s < 3d < 4p < 5s < 4d < 5p < 6s < 4f < 5d < 6p < 7s < 5f < 6d < 7p$$

**Formulae**

1. **Frequency (ν)** = $\frac{c}{\lambda}$

where,

ν = Frequency of electromagnetic radiation

c = Speed of light = 3×10^8 m s⁻¹

λ = Wavelength of electromagnetic radiation

2. **Wave number ($\bar{\nu}$)** = $\frac{1}{\lambda}$

3. **Energy of quantum of radiation (E):**

$$E = h\nu = h \frac{c}{\lambda} = hc\bar{\nu}$$

where, h = Planck's constant = 6.6256×10^{-34} J s

4. **For photoelectric effect:**

$$h\nu = h\nu_0 + \frac{1}{2}mv^2$$

where,

ν_0 = threshold frequency

ν = incident frequency

$\frac{1}{2}mv^2$ = kinetic energy of ejected electron(s)

5. **Energy of an electron (E_n)**

$$= \frac{-2\pi^2mZ^2e^4}{n^2h^2} = -13.6 \frac{Z^2}{n^2} \text{ eV atom}^{-1}$$

6. **Energy of an electron (E_n) in the n^{th} orbit of hydrogen atom:**

$$E_n = -\frac{2.18 \times 10^{-11}}{n} \text{ erg atom}^{-1}$$

$$= -\frac{2.18 \times 10^{-18}}{n^2} \text{ J atom}^{-1}$$

$$= -\frac{13.6}{n^2} \text{ eV atom}^{-1}$$

$$= \frac{1312}{n^2} \text{ kJ mol}^{-1}$$

$$= -\frac{313.6}{n^2} \text{ kcal mol}^{-1}$$

7. **Radius of Bohr's orbit (r)** = $\frac{n^2h^2}{4\pi^2mZe^2}$

$$= 0.529 \times \frac{n^2}{Z} \text{ \AA}$$

8. **Wave number of series of hydrogen spectrum:**

$$\bar{\nu} = R \left[\frac{1}{n_1^2} - \frac{1}{n_2^2} \right]$$

where,

$\bar{\nu}$ = wave number

R = Rydberg constant = $109677.58 \text{ cm}^{-1}$
 $= 1.09677 \times 10^7 \text{ m}^{-1}$

n_1 = lower energy level

n_2 = higher energy level

9. **de Broglie equation:** $\lambda = \frac{h}{mv} = \frac{h}{p}$

$p = mv$ = momentum of particle

10. **Heisenberg's uncertainty principle:**

$$\Delta x \Delta p \geq \frac{h}{4\pi}$$

where, Δx = uncertainty in position,

Δp = uncertainty in momentum

$$\Delta x \times m \Delta v \geq \frac{h}{4\pi} \quad (\because \Delta p = m \Delta v)$$

$$\therefore \Delta x \Delta v \geq \frac{h}{4\pi m}$$

11. **Schrodinger wave equation:**

$$\nabla^2\psi + \frac{8\pi^2m}{h^2}(E - V)\psi = 0$$

where, E = total energy of the system

V = potential energy of the system

ψ = wave function



$$\nabla^2 = \frac{d^2}{dx^2} + \frac{d^2}{dy^2} + \frac{d^2}{dz^2}$$

$$\therefore \frac{d^2\psi}{dx^2} + \frac{d^2\psi}{dy^2} + \frac{d^2\psi}{dz^2} + \frac{8\pi^2m}{h^2}(E - V)\psi = 0$$

12. Orbital angular momentum of an electron (L):

$$L = \frac{h}{2\pi} \sqrt{l(l+1)}$$

where, l = Azimuthal quantum number

13. Number of spherical or radial nodes in an orbital = $(n - l - 1)$

where, n = Principal quantum number

l = Azimuthal quantum number

14. Number of nodal planes in an orbital = l

15. Maximum number of electrons in each principal shell = $2n^2$ electrons

16. Maximum number of electrons in each subshell = $2(2l + 1)$ electrons

17. Maximum number of electrons in each orbital = 2 electrons



Multiple Choice Questions

WAVE NATURE OF LIGHT

1. Distance between the consecutive crests or trough is called _____.

- (A) amplitude (B) frequency
(C) wavelength (D) wave number

2. The radiation with maximum frequency is _____.

[TS EAMCET (Engg.) 2015]

- (A) X-rays (B) radio waves
(C) UV rays (D) IR rays

3. Among the given options, the electromagnetic radiation with the highest wavelength is _____.

- (A) ultraviolet (B) radio waves
(C) X-rays (D) infrared

4. A particular station of All India Radio, New Delhi broadcasts on a frequency of 1368 kHz (kilohertz). The wavelength of the electromagnetic radiation emitted by the transmitter is _____.

[Speed of light, $c = 3.0 \times 10^8 \text{ m s}^{-1}$]

[NEET (UG) 2021]

- (A) 219.2 m (B) 2192 m
(C) 21.92 cm (D) 219.3 m

5. The frequency of a wave of light is $12 \times 10^{14} \text{ sec}^{-1}$. The wave number associated with this light is _____.

- (A) $5 \times 10^7 \text{ m}^{-1}$ (B) $4 \times 10^8 \text{ cm}^{-1}$
(C) $2 \times 10^7 \text{ m}^{-1}$ (D) $4 \times 10^4 \text{ cm}^{-1}$

QUANTUM THEORY OF RADIATION

1. Electron corpuscular nature is NOT connected with _____.

- (A) diffraction phenomenon
(B) photo electric effect
(C) Compton effect
(D) mechanical effect by cathode rays

2. The energy of a photon is calculated by _____.

- (A) $E = hv$ (B) $h = Ev$
(C) $h = \frac{v}{E}$ (D) $E = \frac{h}{v}$

3. Which one of the following is NOT the characteristic of Planck's quantum theory of radiation?

- (A) The energy is not absorbed or emitted in whole number or multiple of quantum.
(B) Radiation is associated with energy.
(C) Radiation energy is not emitted or absorbed continuously but in the form of small packets called quanta.
(D) This magnitude of energy associated with a quantum is proportional to the frequency.

4. Choose the INCORRECT statement.

- (A) Every object emits radiation whose predominant frequency depends on its temperature.
(B) The quantum energy of a wave is proportional to its frequency.
(C) Photons are quanta of light.
(D) The value of Planck constant is energy dependent.

5. Which of the following is CORRECT according to Planck's quantum theory?

- (A) Energy is emitted or absorbed discontinuously.
(B) Energy of a quantum is directly proportional to its frequency.
(C) A photon is also a quantum of light.
(D) All of these

6. The energy of a 700 nm photon is _____.

(Given: $1 \text{ eV} = 1.602 \times 10^{-19} \text{ J}$)

- (A) 1.77 eV (B) 2.47 eV
(C) 700 eV (D) 3.57 eV

7. With regard to photoelectric effect, identify the CORRECT statement among the following.

[KCET 2020]

- (A) Number of e^- ejected increases with the increase in the frequency of incident light.
(B) Number of e^- ejected increases with the increase in work function.
(C) Number of e^- ejected increases with the increase in the intensity of incident light.
(D) Energy of e^- ejected increases with the increase in the intensity of incident light.

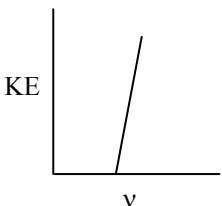
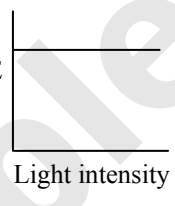

8. When the wavelength of incident light on metallic plate is halved, the K.E. of ejected photoelectron will be _____.
(A) halved
(B) doubled
(C) unchanged
(D) increased more than double
9. Violet light can eject electrons from the surface of a metal, whereas orange light cannot because _____.
(A) the intensity of violet light is greater than that of orange light.
(B) the wavelength of violet light is greater than that of orange light.
(C) the frequency of violet light is greater than that of orange light.
(D) none of these
10. According to photoelectric effect, the kinetic energy of the ejected electrons is directly proportional to _____.
(A) wavelength of light
(B) intensity of light
(C) frequency of light
(D) velocity of incident radiation
11. Which of the following options represent the CORRECT graph for photoelectrons?
(I)  (II) 
(A) Only (I)
(B) Only (II)
(C) Both (I) and (II)
(D) Neither (I) and (II)
12. Light of wavelength λ strikes a metal surface with intensity X and the metal emits γ electrons per second of average energy Z . If X is halved, then, _____.
(A) γ will be halved, Z will be doubled
(B) γ will be doubled, Z will be halved
(C) γ will be halved, Z will remain same
(D) γ will remain the same, Z will be halved
13. Ejection of the photoelectron from metal in the photoelectric effect experiment can be stopped by applying 0.5 V when the radiation of 250 nm is used. The work function of the metal is _____.
(A) 4 eV
(B) 4.5 eV
(C) 5 eV
(D) 5.5 eV
14. The kinetic energy of electron ejected from a metal surface is 0.70 eV. If the work function (W_0) of the metal is 2.30 eV, the frequency of radiation falling on the metal surface in Hz is _____. ($1 \text{ eV} = 1.602 \times 10^{-19} \text{ J}$)
[AP EAMCET (Med.) 2019]
(A) 7.25×10^{13} (B) 1.38×10^{13}
(C) 1.38×10^{14} (D) 7.25×10^{14}
15. If the work function for caesium (Cs) atom is 1.9 eV, then find the approximate value of its threshold wavelength.
[AP EAMCET (Med.) 2020]
(A) 723 nm (B) 480 nm
(C) 654 nm (D) 525 nm
16. Two series of spectral lines of atomic hydrogen which do NOT belong to infrared spectral region are _____. [TS EAMCET (Engg.) 2020]
(A) Lyman and Paschen
(B) Balmer and Brackett
(C) Pfund and Lyman
(D) Lyman and Balmer
17. Which of the following series of transitions in the spectrum of hydrogen atom falls in visible region?
[NEET (UG) 2019]
(A) Balmer series (B) Paschen series
(C) Brackett series (D) Lyman series
18. An electron in hydrogen atom returns from 6th orbital to second orbital by emitting a photon which appears as a line in the spectrum. The region of the spectrum is _____.
(A) radio wave (B) UV
(C) visible (D) infrared
19. For emission line of atomic hydrogen from $n_i = 8$ to $n_f = n$, the plot of wave number ($\bar{\nu}$) against $\left(\frac{1}{n^2}\right)$ will be _____.
(The Rydberg constant, R_H is in wave number unit)
[JEE (Main) Jan 2019]
(A) linear with slope $-R_H$
(B) linear with intercept $-R_H$
(C) non-linear
(D) linear with slope R_H
20. A gas absorbs a photon of wavelength 355 nm and emits at two different wavelengths. If one emission is at 680 nm, the other is at:
(A) 325 nm (B) 518 nm
(C) 743 nm (D) 1035 nm



21. The figure that is a NOT a direct manifestation of the quantum nature of atoms is _____.

[JEE (Main) Sept 2020]

(A)

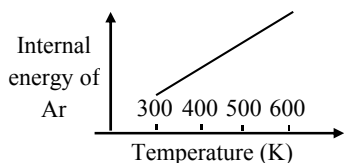

(B)

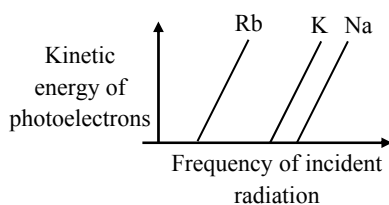

(C)

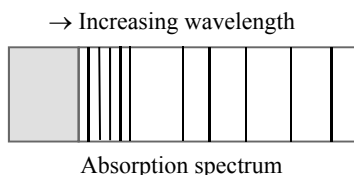

(D)

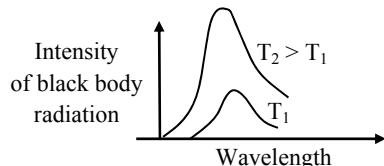

BOHR'S MODEL FOR HYDROGEN ATOM

- The electronic energy levels of the hydrogen atom in the Bohr's theory are called _____.
 (A) orbits (B) orbitals
 (C) subshells (D) both (A) and (B)
- In the Bohr model of an atom, an electron can revolve around in orbits known as _____.
 (A) stationary circular orbits
 (B) stationary elliptical orbits
 (C) radiating circular orbits
 (D) radiating elliptical orbits
- When an electron revolves in a stationary orbit then _____.
 (A) it absorbs energy
 (B) it gains kinetic energy
 (C) it emits radiation
 (D) its energy remains constant
- An electron in a Bohr's stationary orbit can go to a higher stationary orbit _____.
 (A) by emission of electromagnetic radiation
 (B) without any absorption or emission of electromagnetic radiation
 (C) with absorption of electromagnetic radiation of a particular frequency
 (D) none of these

5. The postulate of Bohr theory that electrons jump from one orbit to the other, rather than flow is according to _____.

(A) the quantization concept
 (B) the wave nature of electron
 (C) the probability expression for electron
 (D) Heisenberg uncertainty principle

6. Bohr's model of an atom explains _____.

(A) fine spectra of multi-electron atoms
 (B) spectra of hydrogen atoms
 (C) Stark effect
 (D) Zeeman effect

7. Bohr's model can explain _____.

(A) the spectrum of hydrogen atom only
 (B) spectrum of atom or ion containing one electron only
 (C) the spectrum of hydrogen molecule
 (D) the solar spectrum

8. The Bohr's model of an atom _____.

(A) assumes that the angular momentum of an electron is quantized
 (B) uses Einstein's photoelectric equation
 (C) predicts continuous emission spectra for atoms
 (D) predicts the same emission spectra for all types of atoms

9. If the angular momentum of electron in Bohr's first orbit of hydrogen atom is 'x', then what will be the angular momentum in Bohr's first orbit of He⁺?

(A) x (B) $\frac{x}{2}$
 (C) 2x (D) x^2

10. The energy of an electron revolving in nth Bohr's orbit of an atom is given by the expression _____.

(A) $E_n = -\frac{2\pi^2 m^4 e^2 Z^2}{n^2 h^2}$
 (B) $E_n = -\frac{2\pi^2 m e^2 Z^2}{n^2 h^2}$
 (C) $E_n = -\frac{2\pi^2 m e^4 Z^2}{n^2 h^2}$
 (D) $E_n = -\frac{2\pi m^2 e^2 Z^4}{n^2 h^2}$

11. The energy of electron in the nth Bohr orbit of H-atom is _____. [KCET 2016]

(A) $-\frac{13.6}{n^2}$ eV atom⁻¹ (B) $-\frac{13.6}{n}$ eV atom⁻¹
 (C) $-\frac{13.6}{n^4}$ eV atom⁻¹ (D) $-\frac{13.6}{n^3}$ eV atom⁻¹



12. Energy of the electron in hydrogen atom is given by _____.
- (A) $E_n = -\frac{131.38}{n^2} \text{ kJ mol}^{-1}$
 (B) $E_n = -\frac{131.33}{n} \text{ kJ mol}^{-1}$
 (C) $E_n = -\frac{1313.3}{n^2} \text{ kJ mol}^{-1}$
 (D) $E_n = -\frac{313.13}{n^2} \text{ kJ mol}^{-1}$
13. From the following energy levels of hydrogen atom, the values of E_∞ and E_3 in J are, respectively _____.
- _____ $E_\infty = \dots\dots\dots$
 _____ $E_3 = \dots\dots\dots$
 _____ $E_2 = -0.545 \times 10^{-18} \text{ J}$
 _____ $E_1 = -2.18 \times 10^{-18} \text{ J}$
- [TS EAMCET (Engg.) 2019]
- (A) 1, -0.242×10^{-18}
 (B) ∞ , -0.726×10^{-18}
 (C) 0, -0.242×10^{-18}
 (D) 0, -0.321×10^{-18}
14. The energy of electron in hydrogen atom in its ground state is -13.6 eV . The energy of the level corresponding to n equal to 5 is _____.
- (A) -0.54 eV (B) -0.85 eV
 (C) -0.64 eV (D) -0.40 eV
15. Energy of electron of He^+ in second Bohr orbit is _____.
- (A) $-5.43 \times 10^{-19} \text{ J/atom}$
 (B) $5.43 \times 10^{-19} \text{ J/atom}$
 (C) $2.18 \times 10^{-18} \text{ J/atom}$
 (D) $-2.18 \times 10^{-18} \text{ J/atom}$
16. Which of the following is the energy of a possible excited state of hydrogen? [JEE (Main) 2015]
- (A) $+13.6 \text{ eV}$ (B) -6.8 eV
 (C) -3.4 eV (D) $+6.8 \text{ eV}$
17. The expression for Bohr's radius of an atom is _____.
- (A) $r = \frac{n^2 h^2}{4\pi^2 m e^4 Z^2}$ (B) $r = \frac{n^2 h^2}{4\pi^2 m e^2 Z}$
 (C) $r = \frac{n^2 h^2}{4\pi^2 m e^2 Z^2}$ (D) $r = \frac{n^2 h^2}{4\pi^2 m^2 e^2 Z^2}$
18. Bohr's radius of hydrogen atom is equal to _____.
- (A) $0.529 \times 10^{-8} \text{ cm}$ (B) $0.529 \times 10^{-6} \text{ cm}$
 (C) $0.529 \times 10^{-10} \text{ cm}$ (D) $0.529 \times 10^{-12} \text{ cm}$
19. The radius of the second Bohr orbit for hydrogen atom is _____.
- [Planck's constant, $h = 6.6262 \times 10^{-34} \text{ J s}$
 mass of electron = $9.1091 \times 10^{-31} \text{ kg}$
 charge of electron = $1.60210 \times 10^{-19} \text{ C}$
 permittivity of vacuum,
 $\epsilon_0 = 8.854185 \times 10^{-12} \text{ kg}^{-1} \text{ m}^{-3} \text{ A}^2$]
- [JEE (Main) 2017]
- (A) 1.65 \AA (B) 4.76 \AA
 (C) 0.529 \AA (D) 2.12 \AA
20. The radius of which of the following orbit is same as that of the first Bohr's orbit of hydrogen atom?
- (A) $\text{He}^+(n=2)$ (B) $\text{Li}^{2+}(n=2)$
 (C) $\text{Li}^{2+}(n=3)$ (D) $\text{Be}^{3+}(n=2)$
21. The ratio of radius of first orbit of He^+ to that of Be^{3+} is _____.
- (A) 2 : 1 (B) 1 : 4
 (C) 2 : 3 (D) 1 : 2
22. Choose the INCORRECT relation on the basis of Bohr's theory for hydrogen atom.
- (A) Velocity of electron $\propto \frac{1}{n}$
 (B) Frequency of revolution $\propto \frac{1}{n^3}$
 (C) Radius of orbit $\propto \frac{1}{n^2}$
 (D) Force on electron $\propto \frac{1}{n^4}$
23. The energy of an electron in an orbit of hydrogen like ion with an orbit radius of 52.9 pm in J is _____. (Ground state energy of electron in hydrogen atom is $-2.18 \times 10^{-18} \text{ J}$)
- [AP EAMCET (Engg.) 2019]
- (A) -4.36×10^{-18} (B) -1.09×10^{-17}
 (C) -8.72×10^{-18} (D) -6.54×10^{-18}
24. The speed of the electron (in m s^{-1}) in the third orbit of hydrogen atom is approximately _____. (mass of electron = $9.1 \times 10^{-31} \text{ kg}$)
- [TS EAMCET (Engg.) 2019]
- (A) 3.6×10^5 (B) 2.18×10^5
 (C) 7.26×10^5 (D) 2.18×10^5
25. The circumference of first Bohr's orbit of hydrogen atom is how many times the circumference of second Bohr's orbit of He^+ ?
- (A) Two times (B) Half
 (C) Equal (D) Four times
26. In hydrogen atom, if radius of orbit is made four times that of the smallest orbit, then the angular momentum becomes _____.
- (A) twice (B) half
 (C) four times (D) thrice



27. In H-atom, the ratio of area covered by second orbit to the first orbit is _____.
 (A) 1 : 2 (B) 1 : 16
 (C) 8 : 1 (D) 16 : 1
28. The number of waves made by a Bohr electron in one complete revolution in its 4th orbit is _____.
 [AP EAPCET (Agri. & Pharm.) 2021]
 (A) 1 (B) 2
 (C) 3 (D) 4
29. In the Bohr's model, the first Bohr orbit of hydrogen lies 52.9×10^{-12} m from the nucleus. The centripetal acceleration experienced by the electron in this orbit is _____.
 (A) $9.09 \times 10^{20} \text{ ms}^{-2}$ (B) $9.09 \times 10^{21} \text{ ms}^{-2}$
 (C) $9.09 \times 10^{22} \text{ ms}^{-2}$ (D) $9.09 \times 10^{23} \text{ ms}^{-2}$
30. E_n and J_n denote the total energy and angular momentum of an electron of hydrogen atom in the nth allowed orbit of a Bohr's atom. Then, _____.
 (A) $E_n \propto J_n$ (B) $E_n \propto 1/J_n$
 (C) $E_n \propto J_n^2$ (D) $E_n \propto 1/J_n^2$
31. The energy, the magnitude of angular momentum and orbital radius of an electron in a hydrogen atom corresponding to the quantum number n are E, p and r respectively. Then, according to Bohr's theory of hydrogen atom, _____.
 (A) Epr is proportional to $\frac{1}{n^2}$
 (B) $\frac{p}{E}$ is proportional to $\frac{1}{n^3}$
 (C) Er is constant for all orbits
 (D) pr is independent of n
32. The potential energy of the electron present in the ground state of Li^{2+} ion is represented by _____.
 (A) $+\frac{3ke^2}{r}$ (B) $-\frac{3ke}{r}$
 (C) $-\frac{3ke^2}{r}$ (D) $+\frac{3ke}{r}$
33. Moving away from nucleus in Bohr's atom, the kinetic energy of electron _____.
 (A) decreases
 (B) increases
 (C) unchanged
 (D) first decreases and then increases
34. Which of the following statements is INCORRECT with respect to Bohr's hydrogen atom?
 (A) Kinetic energy of electron is half of the magnitude of its potential energy.
 (B) The total energy of electron is negative.
 (C) Energy of electron decreases with increase in the value of principal quantum number.
 (D) All of these.
35. Which of the following statements is INCORRECT?
 (A) The velocity of electron increases with increase in 'n' value of orbit.
 (B) The energy of electron increases with increase in 'n' value of orbit.
 (C) The kinetic energy of electron decreases with increase in 'n' value of orbit.
 (D) The potential energy of electron increases with increase in 'n' value of orbit.
36. The ratio of potential energy (PE) and total energy of an electron in a Bohr orbit of a hydrogen like atom is _____.
 [TS EAMCET (Med.) 2021]
 (A) 1 (B) 2
 (C) -1 (D) $-\frac{1}{2}$
37. Which of the following transitions have minimum wavelength?
 (A) $n_4 \longrightarrow n_1$ (B) $n_2 \longrightarrow n_1$
 (C) $n_4 \longrightarrow n_2$ (D) $n_3 \longrightarrow n_1$
38. For hydrogen atom, which of the following energy level transitions will result in the emission of a photon with the greatest frequency?
 (A) from n = 6 to n = 3
 (B) from n = 4 to n = 2
 (C) from n = 2 to n = 1
 (D) from n = 1 to n = 4
39. For which of the following species, the electronic transition from n = 5 state to n = 2 state will produce the shortest wavelength in nm?
 [TS EAMCET (Med.) 2020]
 (A) He^+ (B) H
 (C) Li^{2+} (D) Be^{3+}
40. The potential energies of first, second and third Bohr's orbits of He^+ cation are E_1 , E_2 and E_3 . The CORRECT sequence of these energies is:
 (A) $E_1 > E_2 > E_3$ (B) $E_1 = E_2 > E_3$
 (C) $E_1 = E_2 = E_3$ (D) $E_3 > E_2 > E_1$
41. The energy difference between two successive orbits while going away from the nucleus _____.
 (A) increases
 (B) decreases
 (C) remains same
 (D) first decreases and then increases
42. When an electron drops from a higher energy level to a lower energy level in Bohr's atom then _____.
 (A) energy is emitted
 (B) energy is absorbed
 (C) energy is either emitted or absorbed
 (D) none of these



43. The electron with highest energy in Bohr's atom is _____.
- (A) in nucleus
(B) in ground state
(C) in first excited state
(D) at infinite distance from the nucleus
44. If energy change in Bohr's atom is $(\Delta E) = 3 \times 10^{-8}$ J, $h = 6.64 \times 10^{-34}$ Js and $c = 3 \times 10^8$ m/s, then wavelength of the light is _____.
- (A) 6.36×10^3 Å (B) 6.36×10^5 Å
(C) 6.64×10^{-8} Å (D) 6.36×10^{18} Å
45. The λ of spectral line for an electronic transition is inversely proportional to _____.
- (A) the number of electrons undergoing transition
(B) the nuclear charge of the atom
(C) the difference in the energy level involved in the transition
(D) the velocity of electron undergoing transition
46. The energy difference between two electronic states is 46.12 kcal/mole. What will be the frequency of the light emitted when an electron drops from the higher to the lower energy state? (Planck constant = 9.52×10^{-14} kcal sec mole⁻¹)
- (A) 4.84×10^{15} cycles sec⁻¹
(B) 4.84×10^{-5} cycles sec⁻¹
(C) 4.84×10^{-12} cycles sec⁻¹
(D) 4.84×10^{14} cycles sec⁻¹
47. When electron undergoes a transition from one energy level (-7.9 eV) to second energy level (-5.0 eV), then _____.
- (A) it will emit energy equal to 2.9 eV
(B) it will gain potential energy
(C) it will absorb energy equal to 2.9 eV
(D) it will ionise
48. What is the difference in energy between the two electronic energy levels involved in the emission of sodium D₁ line with $\lambda = 5896 \times 10^{-10}$ m? ($h = 6.62 \times 10^{-34}$ J s, $c = 3 \times 10^8$ m s⁻¹)
- (A) 3.0×10^{-18} J
(B) 4.0×10^{-40} J
(C) 3.4×10^{-19} J
(D) 1.3×10^{-48} J
49. If the difference of two energy states in an atom is 6.62×10^{-19} J, then the wavelength of photon emitted as a result of the above transition will be _____.
- (A) 1000 Å (B) 6000 Å
(C) 3000 Å (D) 9000 Å
50. A photon of energy 12.75 eV is completely absorbed by a hydrogen atom, initially in the ground state, so that it is excited. The quantum number of the excited state is _____.
- (A) $n = 1$ (B) $n = 3$
(C) $n = 4$ (D) $n = \infty$
51. The wavelength (in nanometer) of a photon emitted, when the electron goes from $n = 5$ to $n = 3$ level, is _____. ($h = 4.125 \times 10^{-15}$ eV-s)
- (A) 645 (B) 967
(C) 1935 (D) 1280
52. An electron, in hydrogen atom, jumps from $n = 4$ to $n = 2$ state. The change in angular momentum in the transition is _____.
- (A) 1.05×10^{-34} Js (B) 2.1×10^{-34} Js
(C) 3.3×10^{-34} Js (D) 6.6×10^{-34} Js
53. The electron in the hydrogen atom undergoes transition from higher orbit to orbit of radius 211.6 pm. This transition is associated with _____.
- (A) Lyman series (B) Balmer series
(C) Paschen series (D) Brackett series
54. Hydrogen spectrum gave a series of lines at $\frac{5R}{36}$, $\frac{3R}{16}$ and $\frac{21R}{100}$ cm⁻¹ (R=Rydberg constant in cm⁻¹). These lines belong to _____. [TS EAMCET (Med.) 2015]
- (A) Balmer series (B) Lyman series
(C) Pfund series (D) Paschen series
55. Let ν_1 be the frequency of the series limit of the Lyman series, ν_2 be the frequency of the first line of the Lyman series and ν_3 be the frequency of the series limit of the Balmer series. Then, _____.
- (A) $\nu_1 - \nu_2 = \nu_3$ (B) $\nu_2 - \nu_1 = \nu_3$
(C) $\nu_3 = \frac{1}{2}(\nu_1 + \nu_2)$ (D) $\nu_1 + \nu_2 = \nu_3$
56. If the shortest wavelength in Lyman series of hydrogen atom is A, then the longest wavelength in Paschen series of He⁺ is _____.
- (A) $\frac{5A}{9}$ (B) $\frac{5A}{7}$
(C) $\frac{7A}{36}$ (D) $\frac{36A}{7}$
57. An electron in hydrogen atom first jumps from second excited state to first excited state and then from first excited state to ground state. Let the ratio of wavelength, momentum and energy of photons emitted in these two cases be a, b and c respectively. Then, _____.
- (A) $b = \frac{1}{c}$ (B) $a = \frac{27}{5}$
(C) $b = \frac{27}{5}$ (D) $c = a$



58. The amount of energy required for the conversion of H to H⁺ is 13.6 eV. The amount of energy (in eV) required for the conversion of He⁺ to He²⁺ is _____.
- [TS EAMCET (Med.) 2019]
- (A) 27.2 (B) 40.8
(C) 54.4 (D) 81.6

CONCEPT OF SHELLS AND SUBSHELLS

- Choose the CORRECT statement among the following.
 - There are 8 principal electron energy levels.
 - The second principal energy level can have 4 sub energy levels and contains maximum 4 electrons.
 - The Mth energy level can have a maximum of 32 electrons.
 - The L-shell can accommodate 8 electrons.
- Maximum number of electrons present in 'N' shell is _____.

(A) 18 (B) 32 (C) 2 (D) 8
- The maximum number of electrons that can be accommodated in seventh principal shell is _____.

(A) 14 (B) 28 (C) 49 (D) 98

DUAL NATURE OF MATTER: DE BROGLIE'S RELATIONSHIP

- Which of the following expressions gives the de Broglie relationship?

(A) $h = \frac{\lambda}{mv}$ (B) $\lambda = \frac{h}{mv}$
(C) $\lambda = \frac{m}{hv}$ (D) $\lambda = \frac{v}{mh}$
- Wavelength associated with electron motion _____.
 - increases with increase in speed of electron
 - remains same irrespective of speed of electron
 - decreases with increase in speed of electron
 - is zero
- A moving particle may have wave motion, if _____.
 - its mass is very high
 - its velocity is negligible
 - its mass is negligible
 - its mass is very high and velocity is negligible
- The de Broglie wavelength associated with a material particle is _____.
 - directly proportional to its energy
 - directly proportional to momentum
 - inversely proportional to its energy
 - inversely proportional to momentum

5. Which of the following relations is CORRECT, if the wavelength (λ) is equal to the distance travelled by the electron in one second? h is the Planck's constant and m is the mass of electron

[TS EAMCET (Engg.) 2021]

- (A) $\lambda = \frac{h}{p}$ (B) $\lambda = \frac{h}{m}$
(C) $\lambda = \sqrt{\frac{h}{p}}$ (D) $\lambda = \sqrt{\frac{h}{m}}$
- The de Broglie wavelength of a tennis ball of mass 60 g moving with a velocity of 10 metres per second is approximately _____.

(A) 10^{-35} m (B) 10^{-33} m
(C) 10^{-31} m (D) 10^{-16} m
 - The de-Broglie's wavelength of electron present in first Bohr orbit of 'H' atom is _____.

(A) 0.529 Å (B) $2\pi \times 0.529$ Å
(C) $\frac{0.529}{2\pi}$ Å (D) 4×0.529 Å
 - In hydrogen atom, the de Broglie wavelength of an electron in the second Bohr orbit is _____.

[NEET (UG) (Odisha) 2019]

[Given that Bohr radius, $a_0 = 52.9$ pm]

(A) 105.8 pm (B) 211.6 pm
(C) 211.6π pm (D) 52.9π pm
 - If E_e , E_α and E_p represents the kinetic energies of an electron, alpha particle and a proton respectively, each moving with same de Broglie wavelength then _____.

(A) $E_e = E_\alpha = E_p$ (B) $E_e > E_\alpha > E_p$
(C) $E_\alpha > E_p > E_e$ (D) $E_e > E_p > E_\alpha$
 - The relation between wavelength of electron and its kinetic energy is _____.

(A) $\lambda = \frac{h}{KE}$ (B) $\lambda = \frac{h^2}{\sqrt{2KE.m}}$
(C) $\lambda = \frac{nh}{KE}$ (D) $\lambda = \frac{h}{\sqrt{2KE.m}}$
 - Particles A, B and C each with same mass have K.E. of 16E, 4E and E respectively. What is the qualitative order of their de Broglie wavelengths?

(A) $\lambda_A > \lambda_B > \lambda_C$ (B) $\lambda_A = \lambda_B > \lambda_C$
(C) $\lambda_A < \lambda_B < \lambda_C$ (D) $\lambda_A < \lambda_B = \lambda_C$
 - The wavelength of a microscopic particle of mass 9.1×10^{-31} kg is 182 nm, its kinetic energy in J is _____. [AP EAMCET (Engg.) 2019]

(A) 7.28×10^{-23} (B) 7.28×10^{-24}
(C) 3.64×10^{-23} (D) 3.64×10^{-24}



13. The de Broglie wavelength relates to applied voltage as _____.
- (A) $\lambda = \frac{12.3}{\sqrt{h}} \text{ \AA}$ (B) $\lambda = \frac{12.3}{\sqrt{V}} \text{ \AA}$
 (C) $\lambda = \frac{12.3}{\sqrt{E}} \text{ \AA}$ (D) $\lambda = \frac{12.3}{E} \text{ \AA}$
14. If travelling at same speeds, which of the following matter waves have the shortest wavelength? [NCERT Exemplar]
 (A) Electron
 (B) Alpha particle (He^{2+})
 (C) Neutron
 (D) Proton
15. The mass of a photon with a wavelength equal to $1.54 \times 10^{-8} \text{ cm}$ is _____.
 (A) $0.82 \times 10^{-34} \text{ kg}$ (B) $1.28 \times 10^{-33} \text{ kg}$
 (C) $1.43 \times 10^{-32} \text{ kg}$ (D) $1.88 \times 10^{-32} \text{ kg}$
16. What will be the de Broglie wavelength (in metres) of an electron moving with a velocity of $1.2 \times 10^5 \text{ m s}^{-1}$?
 (A) 6.068×10^{-9} (B) 3.133×10^{-37}
 (C) 6.626×10^{-9} (D) 6.018×10^{-35}
17. As per de Broglie's formula, a macroscopic particle of mass 100 gm and moving at a velocity of 100 cm s^{-1} will have a wavelength of _____. [WB JEEM 2014]
 (A) $6.6 \times 10^{-29} \text{ cm}$ (B) $6.6 \times 10^{-30} \text{ cm}$
 (C) $6.6 \times 10^{-31} \text{ cm}$ (D) $6.6 \times 10^{-32} \text{ cm}$
18. A cricket ball of 0.5 kg is moving with a velocity of 100 m/sec. The wavelength associated with its motion is _____.
 (A) $6.6 \times 10^{-34} \text{ m}$ (B) $6.6 \times 10^{-4} \text{ m}$
 (C) $1.32 \times 10^{-35} \text{ m}$ (D) $6.6 \times 10^{-2} \text{ m}$
19. Calculate the de Broglie wavelength of an electron travelling at 1 % of the speed of light.
 (A) 2.73×10^{-24} (B) 2.42×10^{-35}
 (C) 242.2×10^{-10} (D) 2.42×10^{-10}
20. If the velocity of hydrogen molecule is $5 \times 10^4 \text{ cm sec}^{-1}$, then its de Broglie wavelength is _____.
 (A) 2 Å (B) 4 Å
 (C) 8 Å (D) 100 Å
21. An electron has kinetic energy $2.8 \times 10^{-23} \text{ J}$. The de Broglie wavelength will be nearly, _____. ($m_e = 9.1 \times 10^{-31} \text{ kg}$)
 (A) $9.28 \times 10^{-4} \text{ m}$ (B) $9.28 \times 10^{-7} \text{ m}$
 (C) $9.28 \times 10^{-8} \text{ m}$ (D) $9.28 \times 10^{-10} \text{ m}$
22. If two particles A and B are moving with the same velocity, but wavelength of A is found to be double than that of B. Which of the following statements is CORRECT?
 (A) Both A and B have same mass.
 (B) Mass of A is half that of B.
 (C) Mass of B is half that of A.
 (D) Mass of B is one fourth that of A.

HEISENBERG'S UNCERTAINTY PRINCIPLE

1. According to Heisenberg uncertainty principle, _____.
 (A) $E = mc^2$ (B) $\Delta x \times \Delta p \geq \frac{h}{4\pi}$
 (C) $\lambda = h/p$ (D) $\Delta x \times \Delta p = h/6\pi$
2. Both the position and exact velocity of an electron in an atom cannot be determined simultaneously and accurately. This is known as: [TS EAMCET (Med.) 2021]
 (A) de Broglie principle
 (B) Hamiltonian law
 (C) Heisenberg uncertainty principle
 (D) Bohr theory of hydrogen atom
3. If uncertainty in the position of an electron is zero, the uncertainty in its momentum would be, _____.
 (A) Zero (B) $< \frac{h}{2\lambda}$
 (C) $> \frac{h}{2\lambda}$ (D) Infinite
4. The uncertainty in momentum of an electron is $1 \times 10^{-5} \text{ kg m/s}$. The uncertainty in its position will be ($h = 6.62 \times 10^{-34} \text{ kg m}^2/\text{s}$) _____.
 (A) $1.05 \times 10^{-28} \text{ m}$ (B) $1.05 \times 10^{-26} \text{ m}$
 (C) $5.27 \times 10^{-30} \text{ m}$ (D) $5.25 \times 10^{-28} \text{ m}$
5. The uncertainty in the position of a moving bullet of mass 10 gm is 10^{-5} m . Calculate the uncertainty in its velocity.
 (A) $5.2 \times 10^{-28} \text{ m/sec}$
 (B) $3.0 \times 10^{-28} \text{ m/sec}$
 (C) $5.2 \times 10^{-22} \text{ m/sec}$
 (D) $3 \times 10^{-22} \text{ m/sec}$
6. According to Heisenberg's uncertainty principle, the product of uncertainty in position and velocities for an electron of mass $9.1 \times 10^{-31} \text{ kg}$ is _____.
 (A) $2.8 \times 10^{-3} \text{ m}^2 \text{ s}^{-1}$ (B) $2.8 \times 10^{-5} \text{ m}^2 \text{ s}^{-1}$
 (C) $5.8 \times 10^{-5} \text{ m}^2 \text{ s}^{-1}$ (D) $6.8 \times 10^{-6} \text{ m}^2 \text{ s}^{-1}$
7. The uncertainty in the position of an electron (mass = $9.1 \times 10^{-28} \text{ g}$) moving with a velocity of $3.0 \times 10^4 \text{ cm s}^{-1}$ accurate upto 0.001 % will be _____. (Use $\frac{h}{4\pi}$ in the uncertainty expression, where, $h = 6.626 \times 10^{-27} \text{ erg.sec}$)
 (A) 1.92 cm (B) 7.68 cm
 (C) 5.76 cm (D) 3.84 cm



8. The position of both an electron and a helium atom is known within 1.0 nm and the momentum of the electron is known within $50 \times 10^{-26} \text{ kg m s}^{-1}$. The minimum uncertainty in the measurement of the momentum of the helium atom is _____.
- (A) 50 kg m s^{-1}
 (B) 60 kg m s^{-1}
 (C) $80 \times 10^{-26} \text{ kg m s}^{-1}$
 (D) $50 \times 10^{-26} \text{ kg m s}^{-1}$

QUANTUM MECHANICAL MODEL OF AN ATOM: CONCEPT OF ATOMIC ORBITALS

1. Which of the following statements is INCORRECT for Schrodinger's wave equation?
- (A) Schrodinger's wave equation is time dependent.
 (B) ψ is called orbital wave function. It represents the amplitude of electron wave, but has no physical significance.
 (C) ψ^2 is called probability density of electron and always has positive values.
 (D) Schrodinger's wave equation describes the three dimension electron wave.
2. According to Schrodinger's wave equation, which of the following graphs is CORRECT for 2s orbital?

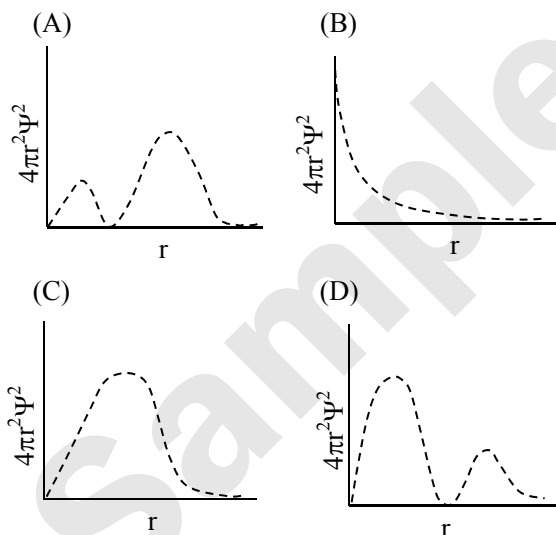

3. Given below are two statements:



Statement I:

The value of wave function, Ψ depends upon the coordinates of the electron in the atom.

Statement II:

The probability of finding an electron at a point within an atom is proportional to the orbital wave function.

In the light of the above statements, choose the CORRECT answer from the options given below: [NEET (UG) Manipur 2023]

- (A) Both Statement I and Statement II are true.
 (B) Both Statement I and Statement II are false.
 (C) Statement I is true but Statement II is false.
 (D) Statement I is false but Statement II is true.

4. The probability density plots of 1s and 2s orbitals are given in the below figure:

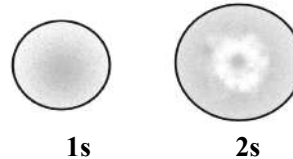

The density of dots in a region represents the probability density of finding electrons in the region.

On the basis of above diagram which of the following statements is INCORRECT?

[NCERT Exemplar]

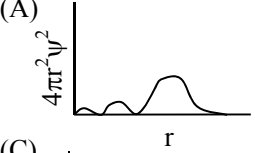
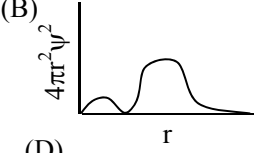
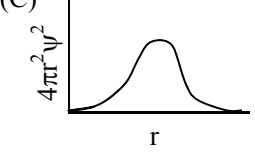
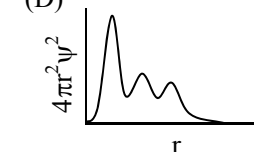
- (A) 1s and 2s orbitals are spherical in shape.
 (B) The probability of finding the electron is maximum near the nucleus.
 (C) The probability of finding the electron at a given distance is equal in all directions.
 (D) The probability density of electrons for 2s orbital decreases uniformly as distance from the nucleus increases.
5. Which of the following statements regarding an orbital is CORRECT?
- (A) An orbital is a definite trajectory around the nucleus in which electron can move.
 (B) An orbital always has spherical trajectory
 (C) An orbital is the region around the nucleus where there is a 90-95 % probability of finding all the electrons of an atom.
 (D) An orbital is characterised by 3 quantum numbers n , l and m .
6. Which of the following radial distribution graphs correspond to 3d orbital?
- (A) 
 (B) 
 (C) 
 (D) 
7. Orbital is a/an _____.
- (A) circular path around the nucleus in which the electron revolves
 (B) space around the nucleus where the probability of finding the electron is maximum
 (C) amplitude of electron wave
 (D) none of these



8. Choose the CORRECT statement among the following.
- (A) ψ^2 represents the atomic orbital.
(B) Except s orbital, all other orbitals are directional.
(C) A node is a point in space around nucleus where the wave function ψ has zero value.
(D) All of these
9. The splitting of the spectral lines under the influence of magnetic field is called _____.
(A) Zeeman effect
(B) Crompton effect
(C) photoelectric effect
(D) diffraction
10. Magnetic quantum number (m) explains _____.
(A) fine hydrogen atomic spectrum
(B) low resolution hydrogen atomic spectrum
(C) spin-spin coupling
(D) Zeeman effect

QUANTUM NUMBERS

1. Which quantum number is NOT related with Schrodinger equation?
(A) Principal (B) Azimuthal
(C) Magnetic (D) Spin
2. The quantum number which specifies the location of an electron as well as energy is _____.
(A) principal quantum number
(B) azimuthal quantum number
(C) spin quantum number
(D) magnetic quantum number
3. The principal quantum number represents _____.
(A) shape of an orbital
(B) distance of electron from the nucleus
(C) number of electrons in an orbit
(D) number of orbitals in an orbit
4. The angular momentum of an electron depends on _____.
(A) principal quantum number
(B) azimuthal quantum number
(C) magnetic quantum number
(D) all of these
5. The shape of an orbital is given by the quantum number _____.
(A) n (B) l
(C) m (D) s
6. Orbital angular momentum depends on _____. [NCERT Exemplar]
(A) l (B) n and l
(C) n and m (D) m and s
7. What is the orbital angular momentum of an electron in 'f' orbital? [MH CET 2014]
(A) $\frac{1.5h}{\pi}$ (B) $\frac{\sqrt{6}h}{\pi}$
(C) $\frac{\sqrt{3}h}{\pi}$ (D) $\frac{\sqrt{3}h}{2\pi}$
8. The magnetic quantum number specifies _____.
(A) size of orbitals
(B) shape of orbitals
(C) orientation of orbitals
(D) nuclear stability
11. Two electrons occupying the same orbital are distinguished by _____. [NEET (UG) P-I 2016]
(A) azimuthal quantum number
(B) spin quantum number
(C) principal quantum number
(D) magnetic quantum number
12. $2p_x$ and $2p_y$ orbitals differ in their _____.
(A) orientation (B) energy
(C) shape (D) ' l ' value
13. An electron having an azimuthal quantum number $l = 3$ is _____.
(A) s-electron (B) p-electron
(C) d-electron (D) f-electron
14. If the principal quantum number of an atom is three, it possesses _____.
(A) only s and p electrons
(B) only p electrons
(C) s, p, d and f electrons
(D) s, p and d electrons
15. $2p$ orbitals have _____.
(A) $n = 1, l = 2$ (B) $n = 1, l = 0$
(C) $n = 2, l = 1$ (D) $n = 2, l = 0$
16. The quantum numbers for the outermost electron of an element are given below as $n = 2, l = 0, m = 0, s = +\frac{1}{2}$. The atom is _____.
(A) lithium (B) beryllium
(C) hydrogen (D) boron
17. If $n = 3$, then the value of ' l ' which is INCORRECT is?
(A) 0 (B) 1
(C) 2 (D) 3
18. The possible values of m for an electron with $l = 1$ are _____. [BCECE (Stage 1) 2016]
(A) $-1, 0, +1$
(B) $0, +1$
(C) $-1, 0$
(D) $-2, -1, 0, +1, +2$



19. The magnetic quantum number for an electron when the value of principal quantum number is 2 can have _____.
 (A) 3 values (B) 2 values
 (C) 9 values (D) 6 values
20. If magnetic quantum number of a given atom is represented by -3 , then what will be its principal quantum number?
 (A) 2 (B) 3
 (C) 4 (D) 5
21. Total number of orbitals associated with third shell will be _____.
 [NCERT Exemplar]
 (A) 2 (B) 4
 (C) 9 (D) 3
22. For $n = 3$ energy level, the number of possible orbitals (all kinds) are _____.
 (A) 1 (B) 3
 (C) 4 (D) 9
23. The number of orbitals associated with quantum numbers $n = 5, m_s = +1/2$ is :
 [JEE (Main) Jan 2020]
 (A) 25 (B) 11
 (C) 15 (D) 50
24. If value of azimuthal quantum number l is 2, then total possible values of magnetic quantum number will be _____.
 (A) 7 (B) 5
 (C) 3 (D) 2
25. If the value of azimuthal quantum number is 3, the possible values of magnetic quantum number would be _____.
 (A) 0, 1, 2, 3 (B) 0, -1, -2, -3
 (C) 0, $\pm 1, \pm 2, \pm 3$ (D) $\pm 1, \pm 2, \pm 3$
26. The relation between n_m , (n_m = the number of permissible values of magnetic quantum number (m)) for a given value of azimuthal quantum number (l), is
 [NEET (UG) 2023]
 (A) $l = 2n_m + 1$ (B) $n_m = 2l^2 + 1$
 (C) $n_m = l + 2$ (D) $l = \frac{n_m - 1}{2}$
27. When the principal quantum number ($n = 3$), the possible values of azimuthal quantum number (l) is _____.
 (A) 0, 1, 2, 3 (B) 0, 1, 2
 (C) -2, -1, 0, 1, 2 (D) 1, 2, 3
28. Which is INCORRECT for $n = 5, m = 3$?
 (A) $l = 4$
 (B) $l = 0, 1, 2, 3; s = +\frac{1}{2}$
 (C) $l = 3$
 (D) All are correct
29. If an electron has spin quantum number of $+\frac{1}{2}$ and a magnetic quantum number of -1 , it CANNOT be presented in a _____.
 (A) d - orbital (B) f - orbital
 (C) p - orbital (D) s - orbital
30. Which one of the following is NOT possible?
 [Assam CEE 2015; WB JEE 2018, 2019]
 (A) $n = 3, l = 0, m = 0$
 (B) $n = 3, l = 1, m = -1$
 (C) $n = 2, l = 0, m = -1$
 (D) $n = 2, l = 1, m = 0$
31. The total magnetic quantum numbers for d-orbital is given by _____.
 (A) 2 (B) 0, $\pm 1, \pm 2$
 (C) 0, 1, 2 (D) 5
32. Which one of the following is the CORRECT set of four quantum numbers (n, l, m, s)?
 [WB JEE 2022]
 (A) $\left(3, 0, -1, +\frac{1}{2}\right)$ (B) $\left(4, 3, -2, +\frac{1}{2}\right)$
 (C) $\left(3, 1, -2, +\frac{1}{2}\right)$ (D) $\left(4, 2, -3, +\frac{1}{2}\right)$
33. INCORRECT set of quantum numbers from the following is: [NEET (UG) Manipur 2023]
 (A) $n = 4, l = 2, m_l = -2, -1, 0, +1, +2, m_s = -1/2$
 (B) $n = 5, l = 3, m_l = -3, -2, -1, 0, +1, +2, +3, m_s = +1/2$
 (C) $n = 4, l = 3, m_l = -3, -2, -1, 0, +1, +2, +3, m_s = -1/2$
 (D) $n = 5, l = 2, m_l = -2, -1, +1, +2, m_s = +1/2$
34. Which of the following sets of quantum numbers is NOT allowed?
 [JEE (Main) July 2022]
 (A) $n = 3, l = 2, m_l = 0, s = +\frac{1}{2}$
 (B) $n = 3, l = 2, m_l = -2, s = +\frac{1}{2}$
 (C) $n = 3, l = 3, m_l = -3, s = -\frac{1}{2}$
 (D) $n = 3, l = 0, m_l = 0, s = -\frac{1}{2}$
35. The energy of an electron in atomic orbital of hydrogen like species depends on _____.
 (A) the principal quantum number only
 (B) the principal and azimuthal quantum numbers only
 (C) the principal, azimuthal and magnetic quantum numbers only
 (D) the principal, azimuthal, magnetic and spin quantum numbers



36. Choose the INCORRECT statement
- (A) The shape of an atomic orbital depends upon the azimuthal quantum number.
- (B) The orientation of an atomic orbital depends upon the magnetic quantum number.
- (C) The energy of an electron in an atomic orbital of multi-electron atom depends on principal quantum number.
- (D) The number of degenerate atomic orbitals of one type depends on the value of azimuthal and magnetic quantum numbers.

SHAPES OF ORBITALS

1. Which orbital is dumb-bell shaped?
- (A) s-orbital (B) p-orbital
(C) d-orbital (D) f-orbital
2. For the dumb-bell shaped orbital, the value of l is _____.
- (A) 3 (B) 1
(C) 0 (D) 2
3. Degenerate orbitals are those which contain _____.
- (A) same orientation
(B) same energy
(C) different energies
(D) none of these
4. The maximum probability of finding an electron in the d_{xy} orbital is _____.
- (A) along the x -axis
(B) along the y -axis
(C) at an angle of 45° from the x and y -axes
(D) at an angle of 90° from the x and y -axes
5. Which of the following pairs of d-orbitals will have electron density along the axis? [NEET (UG) P-II 2016]
- (A) d_{xy} , $d_{x^2-y^2}$
(B) d_{z^2} , d_{xz}
(C) d_{xz} , d_{yz}
(D) d_{z^2} , $d_{x^2-y^2}$
6. Identify the INCORRECT statement from the following. [NEET (UG) 2022]
- (A) In an atom, all the five 3d orbitals are equal in energy in free state.
- (B) The shapes of d_{xy} , d_{yz} and d_{zx} orbitals are similar to each other; and $d_{x^2-y^2}$ and d_{z^2} are similar to each other.
- (C) All the five 5d orbitals are different in size when compared to the respective 4d orbitals.
- (D) All the five 4d orbitals have shapes similar to the respective 3d orbitals.

7. The number of radial nodes present in a given orbital is equal to _____.
- (A) l (B) $n - l$
(C) $n - l - 2$ (D) $n - l - 1$
8. The number of radial nodes for 3p orbital is _____. [NCERT Exemplar]
- (A) 3 (B) 4
(C) 2 (D) 1
9. Number of angular nodes for 4d orbital is _____. [NCERT Exemplar]
- (A) 4 (B) 3
(C) 2 (D) 1
10. The number of angular nodes and radial nodes in 3s orbital are _____. [NEET (UG) P-II 2020]
- (A) 0 and 1, respectively
(B) 0 and 2, respectively
(C) 1 and 0, respectively
(D) 3 and 0, respectively
11. Orbital having 3 angular nodes and 3 total nodes is _____. [NEET (UG) Odisha 2019]
- (A) 6d (B) 5p
(C) 3d (D) 4f

RULES FOR FILLING ELECTRONS IN ORBITALS

1. Which one of the following orders is CORRECT in case of energy of the given electrons?
- P : $n = 4$; $l = 3$ Q : $n = 5$; $l = 2$
R : $n = 5$; $l = 1$ S : $n = 4$; $l = 2$
- [Assam CEE 2015]
- (A) $S < R < P < Q$
(B) $R < P < S < Q$
(C) $Q < S < R < P$
(D) $S < Q < P < R$
2. If the given four electronic configurations
- (i) $n = 4$, $l = 1$ (ii) $n = 4$, $l = 0$
(iii) $n = 3$, $l = 2$ (iv) $n = 3$, $l = 1$
- are arranged in order of increasing energy, then the order will be _____. [WB JEE 2017]
- (A) (iv) < (ii) < (iii) < (i)
(B) (ii) < (iv) < (i) < (iii)
(C) (i) < (iii) < (ii) < (iv)
(D) (iii) < (i) < (iv) < (ii)
3. 4d, 5p, 5f and 6p orbitals are arranged in the order of decreasing energy. The CORRECT option is _____. [NEET (UG) 2019]
- (A) $6p > 5f > 5p > 4d$
(B) $6p > 5f > 4d > 5p$
(C) $5f > 6p > 4d > 5p$
(D) $5f > 6p > 5p > 4d$



4. The two electrons have the following set of quantum numbers:
 $P = 3, 2, -2, +\frac{1}{2}$ $Q = 3, 0, 0, +\frac{1}{2}$
 Which of the following statement is TRUE?
 [KCET 2015]
- (A) P and Q have same energy
 (B) P has greater energy than Q
 (C) P has lesser energy than Q
 (D) P and Q represent same electron
5. Which of the following sets of quantum numbers belong to the highest energy?
- (A) $n = 4, l = 0, m = 0, s = +\frac{1}{2}$
 (B) $n = 3, l = 0, m = 0, s = +\frac{1}{2}$
 (C) $n = 3, l = 1, m = 1, s = +\frac{1}{2}$
 (D) $n = 3, l = 2, m = 1, s = +\frac{1}{2}$
6. The quantum number of four electrons are given below:
 I. $n = 4, l = 2, m_l = -2, m_s = -\frac{1}{2}$
 II. $n = 3, l = 2, m_l = 1, m_s = +\frac{1}{2}$
 III. $n = 4, l = 1, m_l = 0, m_s = +\frac{1}{2}$
 IV. $n = 3, l = 1, m_l = 1, m_s = -\frac{1}{2}$
 The CORRECT order of their increasing energies will be _____.
 [JEE (Main) April 2019]
- (A) $IV < II < III < I$
 (B) $IV < III < II < I$
 (C) $I < III < II < IV$
 (D) $I < II < III < IV$
7. Electron occupies the available orbital singly before pairing in any one orbital occurs, it is _____.
 (A) Pauli's exclusion principle
 (B) Hund's Rule
 (C) Heisenberg's principle
 (D) Aufbau principle
8. In a set of degenerate orbitals, the electrons distribute themselves to retain like spins as far as possible. This statement belongs to _____.
 (A) Pauli's exclusion principle
 (B) Aufbau principle
 (C) Hund's rule of maximum multiplicity
 (D) Slater's rule
9. Quantum numbers of an atom can be defined on the basis of _____.
 (A) Hund's rule
 (B) Aufbau's principle
 (C) Pauli's exclusion principle
 (D) Heisenberg's uncertainty principle
10. "No two electrons in an atom can have the same set of four quantum numbers". This statement is _____.
 [TS EAMCET (Med.) 2019]
- (A) Heisenberg's uncertainty principle
 (B) Particle-wave dualism of de Broglie
 (C) Schrodinger's wave mechanics
 (D) Pauli's exclusion principle
11. How many electrons can fit in the orbital for which $n = 3$ and $l = 1$? [NEET (UG) P-II 2016]
- (A) 14 (B) 2
 (C) 6 (D) 10
12. Nitrogen has the electronic configuration $1s^2, 2s^2, 2p_x^1, 2p_y^1, 2p_z^1$ and not $1s^2, 2s^2, 2p_x^2, 2p_y^1, 2p_z^0$ which is determined by _____.
 (A) Aufbau's principle
 (B) Pauli's exclusion principle
 (C) Hund's rule
 (D) uncertainty principle
13. Which electronic configuration for oxygen is CORRECT according to Hund's rule of multiplicity?
 (A) $1s^2, 2s^2, 2p_x^2, 2p_y^1, 2p_z^1$
 (B) $1s^2, 2s^2, 2p_x^2, 2p_y^2, 2p_z^0$
 (C) $1s^2, 2s^2, 2p_x^3, 2p_y^1, 2p_z^0$
 (D) $1s^2, 2s^2, 2p_x^0, 2p_y^2, 2p_z^2$
14. Which of the following electronic configuration is NOT possible according to Hund's rule?
 (A) $1s^2, 2s^2$
 (B) $1s^2, 2s^1$
 (C) $1s^2, 2s^2, 2p_x^1, 2p_y^1, 2p_z^1$
 (D) $1s^2, 2s^2, 2p_x^2$
15. Which one is a WRONG statement?
 [NEET (UG) 2018]
- (A) Total orbital angular momentum of electron in 's' orbital is equal to zero.
 (B) An orbital is designated by three quantum numbers while an electron in an atom is designated by four quantum numbers.
 (C) The electronic configuration of N atom is
 $1s^2 \quad 2s^2$

 (D) The value of m for d_{z^2} is zero.

**ELECTRONIC CONFIGURATIONS OF ATOMS**

- Electronic configuration of H^- is _____.
(A) $1s^0$ (B) $1s^1$
(C) $1s^2$ (D) $1s^1 2s^1$
- An element has the electronic configuration $1s^2, 2s^2, 2p^6, 3s^2, 3p^2$. Its valency electrons are _____.
(A) 6 (B) 2 (C) 3 (D) 4
- Which one of the following configuration represents a noble gas?
(A) $1s^2, 2s^2, 2p^6, 3s^2$
(B) $1s^2, 2s^2, 2p^6, 3s^1$
(C) $1s^2, 2s^2, 2p^6$
(D) $1s^2, 2s^2, 2p^6, 3s^2, 3p^6, 4s^2$
- The electronic configuration of silver atom in ground state is _____.
(A) $[Kr] 3d^{10} 4s^1$ (B) $[Xe] 4f^{14} 5d^{10} 6s^1$
(C) $[Kr] 4d^{10} 5s^1$ (D) $[Xe] 4d^9 5s^2$
- Krypton (${}_{36}Kr$) has the electronic configuration $[{}_{18}Ar] 4s^2 3d^{10} 4p^6$. The 37th electron will go into which one of the following sub-levels?
(A) 4d (B) 4f (C) 5s (D) 3p
- The total number of unpaired electrons in d-orbital of atom of an element of atomic number 29 is _____.
(A) 10 (B) 1 (C) 0 (D) 5
- The atomic number of an element having the valence shell electronic configuration $4s^2 4p^6$ is _____.
(A) 35 (B) 36 (C) 37 (D) 38
- The atomic number of an element is 35 and mass number is 81. The number of electrons in the outermost shell is _____.
(A) 7 (B) 6 (C) 5 (D) 3
- The atomic number of an element is 35. What is the total number of electrons present in all the p-orbitals of the ground state atom of that element?
(A) 6 (B) 11 (C) 17 (D) 23

STABILITY OF HALF FILLED AND COMPLETELY FILLED ORBITALS

- Which of the following statements is NOT correct?
(A) Extra stability of half filled and completely filled orbitals among s and p block elements is reflected in trends of ionisation enthalpy across a period.
(B) Extra stability of half filled and completely filled orbitals among s and p block elements is reflected in electron affinity trends across a period.

- (C) Aufbau principle is incorrect for cases where energy difference between ns and $(n-1)d$ subshell is larger.
(D) Extra stability to half filled subshell is due to higher exchange energies.

- Which one is the WRONG statement?

[NEET (UG) 2017]

- (A) de-Broglie's wavelength is given by $\lambda = \frac{h}{mv}$, where m = mass of the particle, v = group velocity of the particle.
(B) The uncertainty principle is $\Delta E \times \Delta t \geq \frac{h}{4\pi}$.
(C) Half filled and fully filled orbitals have greater stability due to greater exchange energy, greater symmetry and more balanced arrangement.
(D) The energy of 2s orbital is less than the energy of 2p orbital in case of hydrogen like atoms.

- The CORRECT ground state electronic configuration of chromium atom is _____.

- (A) $[Ar] 3d^5 4s^1$ (B) $[Ar] 3d^4 4s^2$
(C) $[Ar] 3d^6 4s^0$ (D) $[Ar] 4d^5 4s^1$

- The pair of ions having same electronic configuration is _____.

[NCERT Exemplar]

- (A) Cr^{3+}, Fe^{3+} (B) Fe^{3+}, Mn^{2+}
(C) Fe^{3+}, Co^{3+} (D) Sc^{3+}, Cr^{3+}

- Which of the following options does NOT represent ground state electronic configuration of an atom?

[NCERT Exemplar]

- (A) $1s^2 2s^2 2p^6 3s^2 3p^6 3d^8 4s^2$
(B) $1s^2 2s^2 2p^6 3s^2 3p^6 3d^9 4s^2$
(C) $1s^2 2s^2 2p^6 3s^2 3p^6 3d^{10} 4s^1$
(D) $1s^2 2s^2 2p^6 3s^2 3p^6 3d^5 4s^1$

- Mo atom in its ground state has a $4d^5 5s^1$ configuration and Ag atom $4d^{10} 5s^1$ configuration. This is because a shell which is half filled or completely filled is particularly _____.

- (A) strongly destabilized due to higher exchange energies
(B) weakly stabilized due to higher exchange energies
(C) weakly destabilized due to higher exchange energies
(D) strongly stabilized due to higher exchange energies



MISCELLANEOUS

- The statement that is INCORRECT is _____.
[KCET 2014]
 - angular quantum number signifies the shape of the orbital
 - energies of stationary states in hydrogen like atoms is inversely proportional to the square of the principal quantum number
 - total number of nodes for 3s orbital is three
 - the radius of the first orbit of He^+ is half that of the first orbit of hydrogen atom
- Bohr's model of atom is contradicted by _____.
 - Pauli's exclusion principle
 - Planck quantum theory
 - Heisenberg uncertainty principle
 - all of these
- The energy of which of the following systems is NOT quantized?
 - A particle in a box
 - A particle in free space
 - A rigid rotor
 - A simple harmonic oscillator
- Which one is INCORRECT relation in the following?
 - $h = \frac{E}{\nu}$
 - $E = mc^2$
 - $\Delta x \times \Delta p = \frac{h}{4\pi}$
 - $\lambda = \frac{h}{mv}$
- Which one of the following corresponds to a photon of the highest energy?
[WB JEE 2017]
 - $\lambda = 300 \text{ nm}$
 - $\nu = 3 \times 10^8 \text{ s}^{-1}$
 - $\bar{\nu} = 30 \text{ cm}^{-1}$
 - $E = 6.626 \times 10^{-27} \text{ J}$
- The velocity of electron in first orbit of H-atom as compared to the velocity of light is about _____.
 - $\left(\frac{1}{10}\right)^{\text{th}}$
 - $\left(\frac{1}{10000}\right)^{\text{th}}$
 - $\left(\frac{1}{100}\right)^{\text{th}}$
 - same
- For an electron in a hydrogen atom, the wave function ψ is proportional to \exp^{-r/a_0} where, a_0 is the Bohr's radius. What is the ratio of the probability of finding the electron at the nucleus to the probability of finding it at a_0 ?
 - e
 - e^2
 - $\frac{1}{e^2}$
 - zero
- Which of the following electron is the most tightly bound to the nucleus?
[Assam CEE 2017]
 - 4s
 - 4p
 - 4d
 - 4f
- The orbital nearest to the nucleus is _____.
[KCET 2018]
 - 4f
 - 5d
 - 5s
 - 7p
- A stream of electrons from a heated filament was passed between two charged plates kept at a potential difference V esu. If e and m are charge and mass of an electron, respectively, then the value of h/λ . (where λ is wavelength associated with electron wave) is given by _____.
[JEE (Main) 2016]
 - 2meV
 - $\sqrt{\text{meV}}$
 - $\sqrt{2\text{meV}}$
 - meV
- When uranium is bombarded with neutrons, it undergoes fission. The fission fragments are krypton and barium. The fission reaction can be written as,

$${}_{92}\text{U}^{235} + {}_0\text{n}^1 \longrightarrow {}_{56}\text{Ba}^{141} + {}_{36}\text{Kr}^{92} + 3\text{X} + \text{Q}$$
 where the three particles denoted by X are produced and energy Q is released. The particle X is _____.
 - electron
 - proton
 - neutron
 - photon
- Which of the following statements does NOT represent a part of Bohr's model of the hydrogen atom?
 - Energy of the electrons in the orbit is quantized.
 - The electron in the orbit nearest the nucleus has the lowest energy.
 - Electrons revolve in different orbits around the nucleus.
 - The position and velocity of the electrons in the orbit cannot be determined simultaneously.
- For the electrons of oxygen atom, which of the following statements is CORRECT?
[NCERT Exemplar]
 - Z_{eff} for an electron in a 2s orbital is the same as Z_{eff} for an electron in a 2p orbital.
 - An electron in the 2s orbital has the same energy as an electron in the 2p orbital.
 - Z_{eff} for an electron in 1s orbital is the same as Z_{eff} for an electron in a 2s orbital.
 - The two electrons present in the 2s orbital have spin quantum numbers 's' but of opposite sign.



14. Which of the following statements is FALSE?
 (A) Photon has momentum as well as wavelength.
 (B) Splitting of spectral lines in electrical field is called Stark effect.
 (C) Rydberg constant has unit of energy.
 (D) Frequency of emitted radiation from a black body goes from a lower wavelength to higher wavelength as the temperature increases.

15. The set of quantum numbers $n = 3, l = 0, m = 0, s = -\frac{1}{2}$ belongs to the element _____.

(A) Mg (B) Li (C) Ne (D) F

16. The CORRECT set of four quantum number for the valence electrons of rubidium atom ($Z = 37$) is _____.

[JEE (Main) 2014]

(A) 5, 0, 0, +1/2 (B) 5, 1, 0, +1/2
 (C) 5, 1, 1, +1/2 (D) 5, 0, 1, +1/2

17. The four quantum numbers of the valence electron of potassium are _____.

(A) 4, 1, 0 and $\frac{1}{2}$ (B) 4, 0, 1 and $\frac{1}{2}$
 (C) 4, 0, 0 and $+\frac{1}{2}$ (D) 4, 1, 1 and $\frac{1}{2}$

18. Which of the following sets of quantum numbers is CORRECT for the 19th electron of chromium?
 [WB JEE 2017]

	n	l	m	s
(A)	3	0	0	$\frac{1}{2}$
(B)	3	2	-2	$\frac{1}{2}$
(C)	4	0	0	$\frac{1}{2}$
(D)	4	1	-1	$\frac{1}{2}$

19. The maximum number of electrons in an atom in which the last electron filled has the quantum numbers $n = 3, l = 2$ and $m = -1$ is _____.

[WB JEE 2020]

(A) 17 (B) 27
 (C) 28 (D) 30

20. According to Hund's rule which element contains six unpaired electron?

(A) Fe (B) Co
 (C) Ni (D) Cr

21. An atom has 2 electrons in K shell, 8 electrons in L shell and 6 electrons in M shell. The number of s-electrons present in the s-orbital of the atom is _____.

(A) 6 (B) 5
 (C) 7 (D) 10

22. The size of the iso-electronic species Cl^- , Ar and Ca^{2+} is affected by _____.

[JEE (Main) April 2019]

(A) principal quantum number of valence shell
 (B) nuclear charge
 (C) electron-electron interaction in the outer orbitals
 (D) azimuthal quantum number of valence shell

23. Match the following

	List - I		List - II
i.	Nodes	a.	Three dimensional shape of the orbital
ii.	Subsidiary quantum number	b.	Significant only for motion of microscopic objects
iii.	White light	c.	$ \psi ^2$ is zero
iv.	Heisenberg's uncertainty principle	d.	Spin state of electron
		e.	Continuous spectrum

[TS EAMCET (Engg.) 2019]

(A) i - e, ii - d, iii - b, iv - a
 (B) i - e, ii - d, iii - e, iv - b
 (C) i - d, ii - c, iii - b, iv - a
 (D) i - c, ii - a, iii - e, iv - b

24¹³ Numerical Value Type Questions

1. Following figure shows spectrum of an ideal black body at four different temperatures. The number of CORRECT statements from the following is _____.

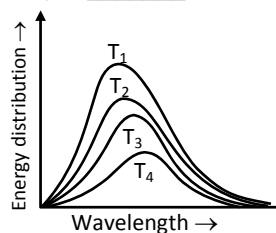

- i. $T_4 > T_3 > T_2 > T_1$
 ii. The black body consists of particles performing simple harmonic motion.
 iii. The peak of spectrum shifts to shorter wavelength as temperature increases.
 iv. $\frac{T_1}{v_1} = \frac{T_2}{v_2} = \frac{T_3}{v_3} \neq \text{constant}$
 v. The given spectrum could be explained using quantisation of energy.



- For principal quantum number $n = 4$, the total number of orbitals having $l = 3$ are _____.
- The radius of the third Bohr orbit for H-atom is _____ Å. (Round off answer to the nearest integer)
- The number of spherical nodes in 2s orbital is/are _____.
- A photon of light having energy, E , has a wavelength equal to 750 nm. The wavelength of photon that corresponds to energy, $5E$ is _____ nm.
- What is the possible number of spectral lines obtained when an electron of a hydrogen atom jumps from the 6th orbit to 1st orbit?



- An atom has 2 electrons in K shell, 8 electrons in L shell and 6 electrons in M shell. The number of electrons having $l = 1$ is _____.
- A proton and a Li^{3+} nucleus are accelerated by the same potential. If λ_{Li} and λ_{p} denote the de Broglie wavelengths of Li^{3+} and proton respectively, then the value of $\frac{\lambda_{\text{Li}}}{\lambda_{\text{p}}}$ is $x \times 10^{-1}$. The value of x is _____. (Rounded off to the nearest integer) [Mass of $\text{Li}^{3+} = 8.3$ mass of proton] [JEE (Main) Feb 2021]

Topic Test

- In the ground state of an atom, the orbitals are filled in the order of their increasing energies. Which of the following orbitals will be filled first?
(A) 5s (B) 4p
(C) 3d (D) 4s
- Calculate the energy of a photon of radiation with wavelength of 300 nm.
(A) 6.626×10^{-9} J
(B) 6.626×10^{-10} J
(C) 6.626×10^{-18} J
(D) 6.626×10^{-19} J
- Which of the following set of quantum number is NOT valid?
(A) $n = 1, l = 2$ (B) $n = 2, m = 1$
(C) $n = 3, l = 0$ (D) $n = 4, l = 2$
- The total number of radial nodes for 4s orbital is _____.
(A) 0 (B) 1 (C) 2 (D) 3
- The series of lines present in the ultraviolet region of the hydrogen spectrum is _____.
(A) Lyman (B) Balmer
(C) Paschen (D) Pfund
- Principal quantum number of an atom represents _____.
(A) size of the Shell
(B) spin angular momentum
(C) orbital angular momentum
(D) space orientation of the orbital
- The four quantum numbers for the valence shell electron or last electron of sodium ($Z = 11$) are _____.
(A) $n = 2, l = 1, m = -1, s = -\frac{1}{2}$
(B) $n = 3, l = 0, m = 0, s = +\frac{1}{2}$

- (C) $n = 3, l = 2, m = -2, s = -\frac{1}{2}$
(D) $n = 3, l = 2, m = 2, s = +\frac{1}{2}$

- According to Bohr's principle for hydrogen atom, the relation between principal quantum number (n) and radius of orbit is _____.
(A) $r \propto n$ (B) $r \propto n^2$
(C) $r \propto \frac{1}{n}$ (D) $r \propto \frac{1}{n^2}$
- The energy of second Bohr orbit of the hydrogen atom is -328 kJ mol^{-1} . The energy of fourth Bohr orbit would be _____.
(A) -41 kJ mol^{-1} (B) $-1312 \text{ kJ mol}^{-1}$
(C) -164 kJ mol^{-1} (D) -82 kJ mol^{-1}
- When a hydrogen atom is bombarded by electrons, the atom is excited to the $n = 4$ state of hydrogen atom. The energy released, when the atom goes from $n = 4$ state to the ground state is _____.
(A) 1.275 eV (B) 12.75 eV
(C) 5 eV (D) 8 eV
- The de Broglie wavelength of a particle with mass 1 g and velocity of 100 m/s is _____. [h is Planck's constant = $6.626 \times 10^{-34} \text{ J s}$]
(A) $h \times 10 \text{ m}$ (B) $h \times 100 \text{ m}$
(C) $h \text{ m}$ (D) $h \times 0.1 \text{ m}$
- In Heisenberg's uncertainty equation _____.
 $\Delta x \cdot \Delta p \geq \frac{h}{4\pi}$; Δp stands for
(A) uncertainty in energy
(B) uncertainty in velocity
(C) uncertainty in momentum
(D) uncertainty in mass



13. For an s orbital, the magnetic quantum number has value _____.
(A) 2 (B) 4 (C) -1 (D) 0
14. For p_z orbital, _____ is a nodal plane.
(A) Z-axis (B) XY plane
(C) ZY plane (D) XZ plane
15. The wave number ($\bar{\nu}$) of yellow light having $\lambda = 580 \text{ nm}$, emitted from a sodium lamp is _____.
(A) $1.724 \times 10^{-6} \text{ m}^{-1}$ (B) $1.724 \times 10^{-3} \text{ m}^{-1}$
(C) $1.724 \times 10^6 \text{ m}^{-1}$ (D) $1.724 \times 10^9 \text{ m}^{-1}$
16. The space around the nucleus of atom where the $\psi^2 > 90\%$ is called _____.
(A) nodal plane (B) atomic orbital
(C) nodal region (D) molecular orbital
17. The wavelength of a 200 g rubber ball moving with a velocity 50 m s^{-1} is _____.
(A) $6.626 \times 10^{-35} \text{ m}$ (B) $6.626 \times 10^{-38} \text{ m}$
(C) $6.626 \times 10^{-32} \text{ m}$ (D) $6.626 \times 10^{-34} \text{ m}$
18. The relationship between potential and the wavelength of electron is given as _____.
(A) $\frac{h^2}{2m\lambda^2e}$ (B) $\frac{h}{\lambda\sqrt{2me}}$
(C) $\frac{h^2e}{2m\lambda^2}$ (D) $\frac{2m\lambda^2e}{h^2}$
19. The number of orbitals (all kinds) for in the fourth principal quantum number will be _____.
(A) 4 (B) 8
(C) 12 (D) 16
20. The angular momentum of an electron revolving in L-shell of hydrogen atom is given as _____.
(A) $\frac{h}{2\pi}$ (B) $\frac{2h}{\pi}$ (C) $\frac{3h}{2\pi}$ (D) $\frac{h}{\pi}$

Scan the adjacent Q.R. Code in *Quill - The Padhai App* to access Answers & Solutions to Topic Test.



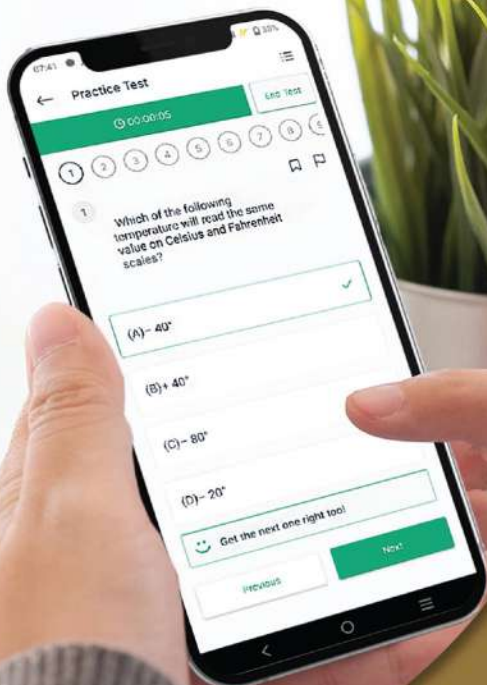

Give your NEET & JEE exam preparation the
TECHNOLOGY BOOST!

Practice more than
17,000 MCQs
for just **₹749/-**

Use Coupon Code
QUILLPADHAI2023



Also available for **Xth, XIth, XIIth & MHT-CET**

- Practice chapter-wise & full syllabus MCQs in test format
- Get instant verification of your answer
- Detailed analysis of every test on completion
- Option to save questions for future reference



Scan QR Code
to download
the app

Visit our website to know more about our
range of books for **Xth, XIth, XIIth & MHT-CET**

Visit Our Website

Published by:

Target Publications[®] Pvt. Ltd.
Transforming lives through learning

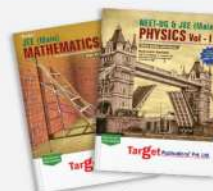

Explore our range of
NEET & JEE Books

B2, 9th Floor, Ashar, Road No. 16/Z, Wagle Industrial Estate, Thane (W)-400604 | 88799 39712 / 14 | 88799 39713 / 15

www.targetpublications.org | mail@targetpublications.org